

High performance butterfly valve

Fig.263W : Wafer

Fig.263L : Lug



www.coreline.dk

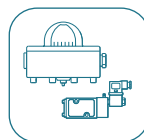
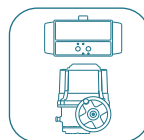
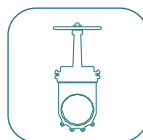
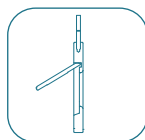
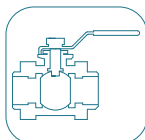
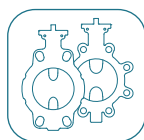

General specifications

General specifications

Nominal diameter:	DN50 - DN600 (Bigger sizes available on request)
Connection:	Wafer, lug
Flange accommodation:	PN10/16//25/40 Class150/300
Face to face:	API609 Table 2
Material:	Carbon steel, Stainless steel
Temperature range:	-40 °C ~ +260 °C (depending on pressure, medium and material)
Tightness test:	API598

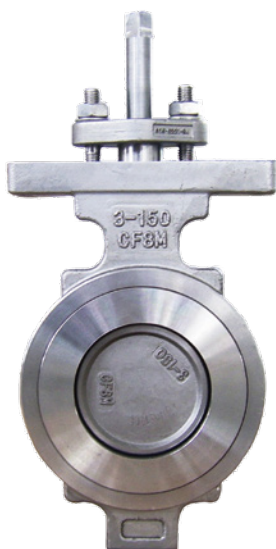

Index

page 3	Design features
page 4	Structures
page 5	Different options
page 6	Material part list
page 7	Dimensions - Wafer type Class150, PN10/16/20
page 8	Dimensions - Lug type Class150
page 9	Dimensions - Wafer type Class300, PN25/40
page 10	Torque values, Cv values
page 11	Cv curves
page 12	Technical data

Design features

General features

- Double eccentric bidirectional sealing.
- Disc with eccentric spherical shape.
- Dynamic lip design of seat with zero leakage on both sides.
- Low torque figures reduces cost for actuator and ensure longer lifetime.
- Different packing options, including life loaded.

Integral structure of the valve

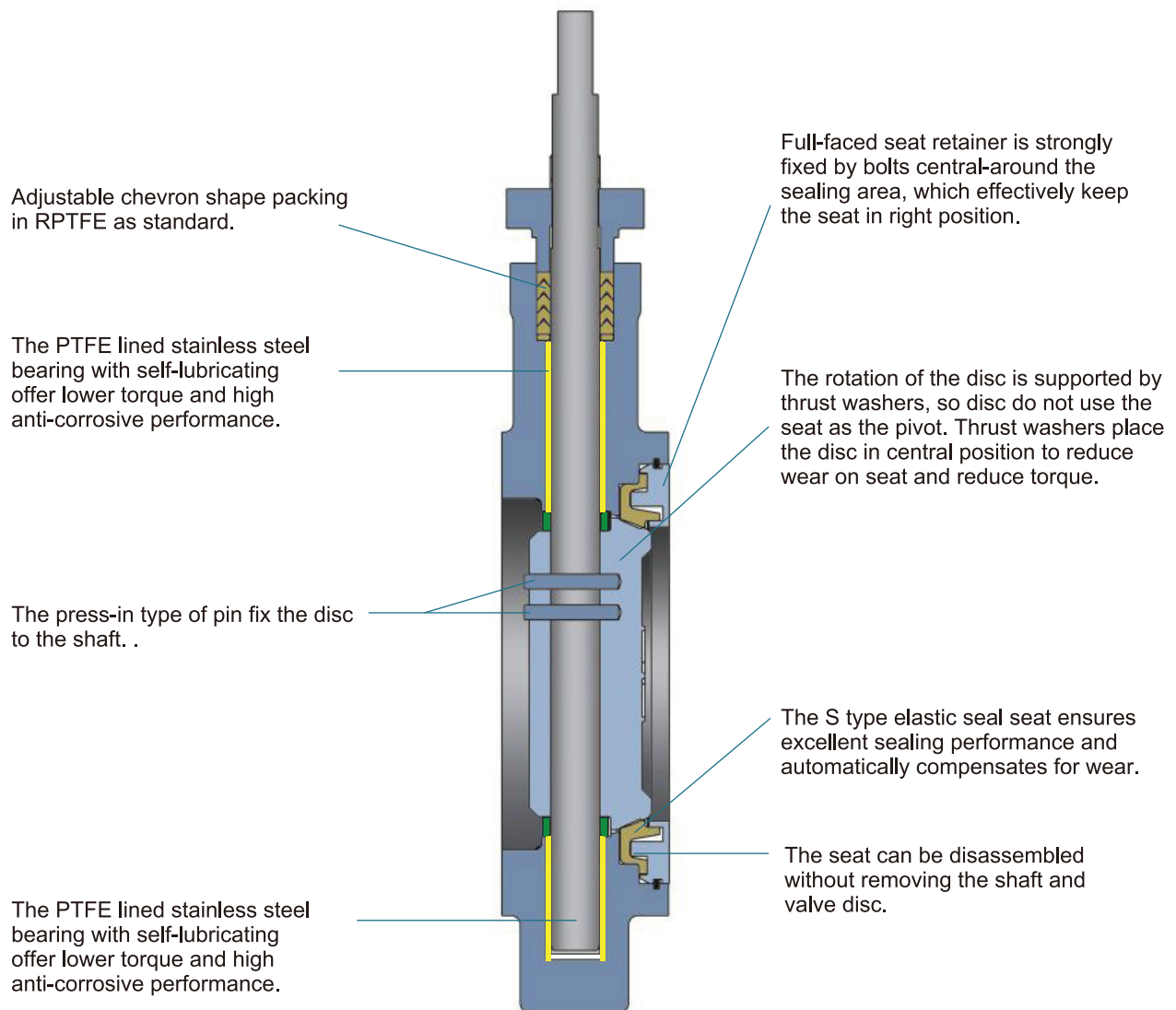

Double offset stem and disc design

The double offset design reduces the seat wear as well as ensures the bidirectional sealing with zero leakage.

- No contact between the seat and the disc, when the valve is in open position.
- No wearing points at the upper and lower parts of the seat.
- Low torque valve which saves the operation costs.

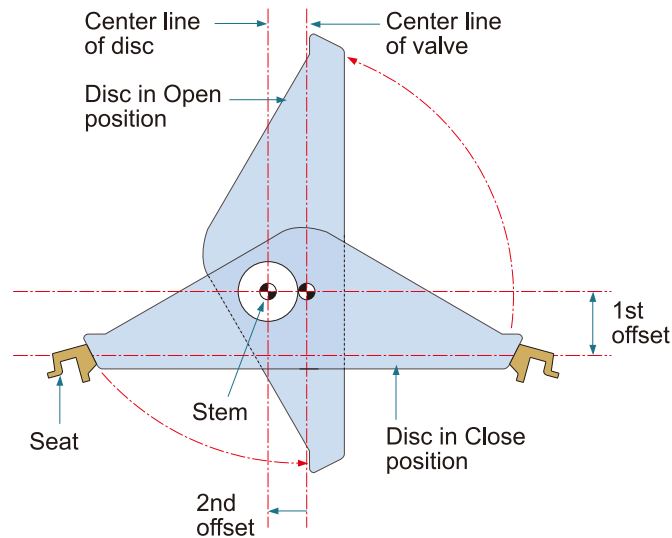

Unique seat sealing structure

The S type elastic seat of Fig.263 high performance butterfly valve uses a good elasticity and long service life RPTFE material as standard. The special sealing design can automatically compensate for the changes of temperature and pressure, and it can also offer sealing compensation due to the wearing of seat during usage. The seat can be replaced by removing the seat retainer without disassembling shaft and valve.

Fig.263 high performance butterfly valve can achieve as prescribed no bubble sealing according to MSS-SP61.

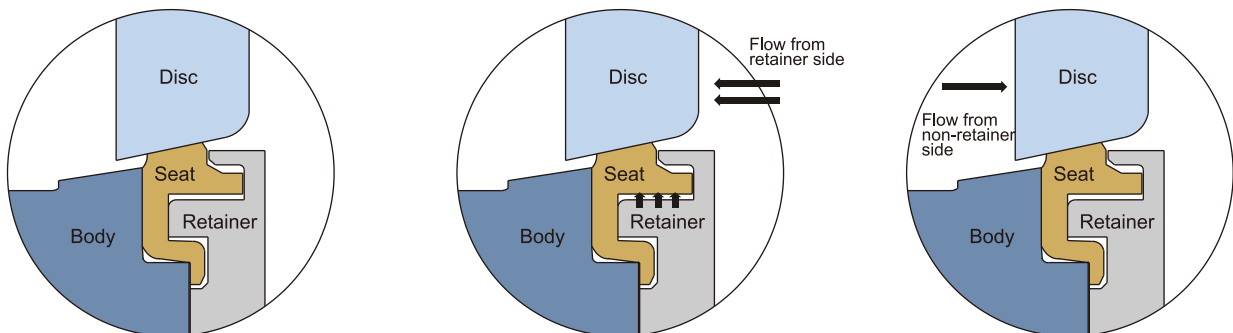

When the valve is closed, the closing disc makes the seat slightly deform. The deformation excites the seat. The excitation of the seat sealing face enables tight sealing to be maintained between the seat and the disc edge.

Flow from the seat retainer side: the pressure is exerted at the bottom of the seat edge - which can further enhance the sealing force between the disc and the seat.

Flow from non-retainer side: the disc will be pushed towards the seat. As the disc is with eccentric spherical shape, the further the disc is pushed towards the seat, the tighter the valve is closed. The groove contact between the seat and the retainer can limit the excessive movement of the seat.

Different options

Gland packing options

Fig.263 high performance butterfly valves use a set of V-rings as standard gland packing.

We can also offer enhanced life-loaded packing to provide the customer with worry free control of emissions.
OBS: The operating torque of valves with live-loaded packing system might increase torque and there would be MOQ requirement.

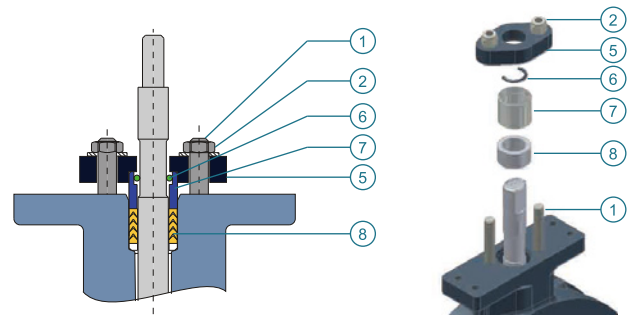

Packing sealing system
Standard

Gland packing part list

Item No.	Part name
1	Gland stud
2	Nut
3	Spring
4	Sleeve
5	Gland flange
6	Anti-blowout ring
7	Bushing
8	V-packing
9	Monitoring ring

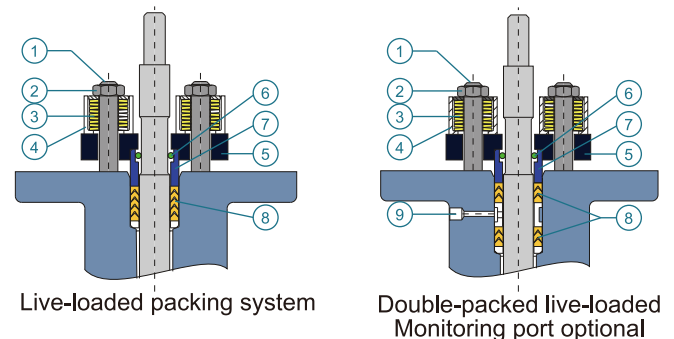

Live-loaded packing system

Double-packed live-loaded
Monitoring port optional

Fire resistant type available

The fire resistant type butterfly valve is designed according to API607. In the event of fire at the during usage of the valve, when the seal ring made of non-metal materials such as PTFE is decomposed or damaged under high temperature, the metal can be used to help the internal pressure self-sealing structure and play the function of auxiliary sealing, so as to effectively prevent media from large amounts of leakage and stop fire spreading.

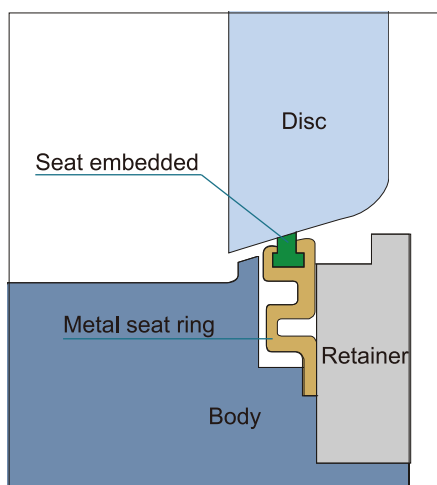

Before fire

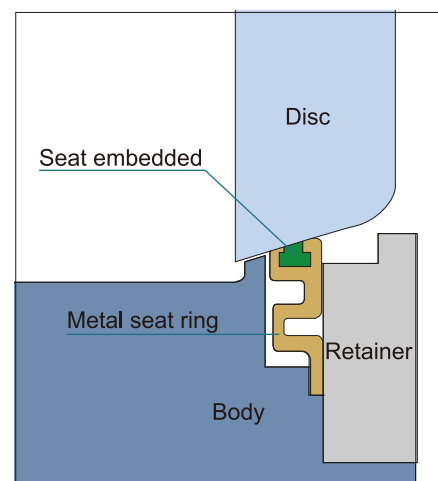

During fire and after fire

Material part list

Wafer type

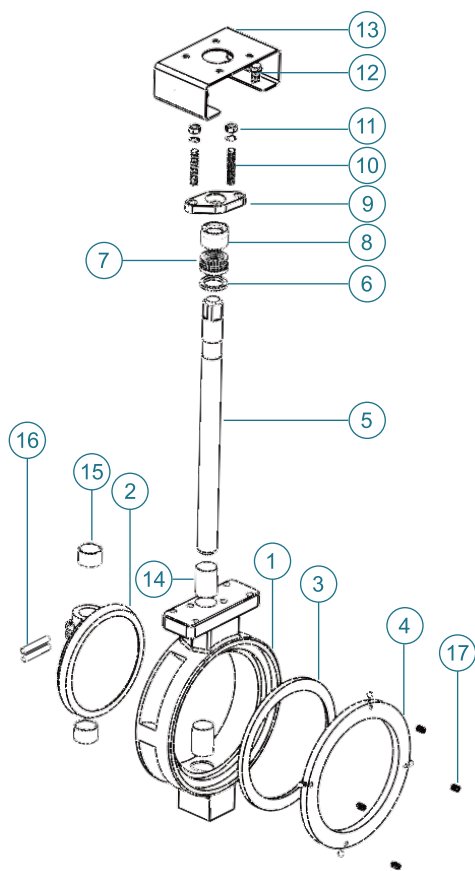

Lug type

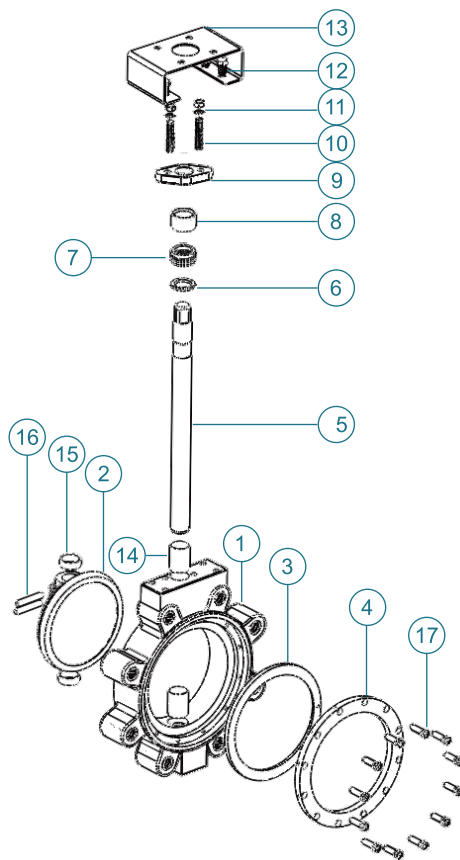

Item No.	Part name	Material
1	Body	WCB / CF8 / CF8M / CF3M
2	Disc	CF8 / CF8M / CF3M
3	Seat	RPTFE / PPL
4	Seat retainer	20# / CF8 / CF8M / CF3M
5	Stem	17-4 PH / SS316
6	Spacer	SS316
7	V-packing	RPTFE / PPL
8	Gland bearing	SS316
9	Gland flange	CF8
10	Gland stud	SS304 / SS316
11	Nut+spring washer	SS304 / SS316
12	Bracket bolt	SS304 / SS316
13	Bracket	WCB / CF8 / CF8M
14	Bearing	316+RPTFE
15	Thrust bearing	SS316
16	Pin	17-4 PH / SS316
17	Screw	SS304 / SS316

Notes:

- 1) Please contact Coreline if you need other materials.
- 2) Temperature range: RPTFE: -30 ~ +210 C; PPL: -20 ~ +240 C.

Dimensions - Wafer type Class150, PN10/16/20

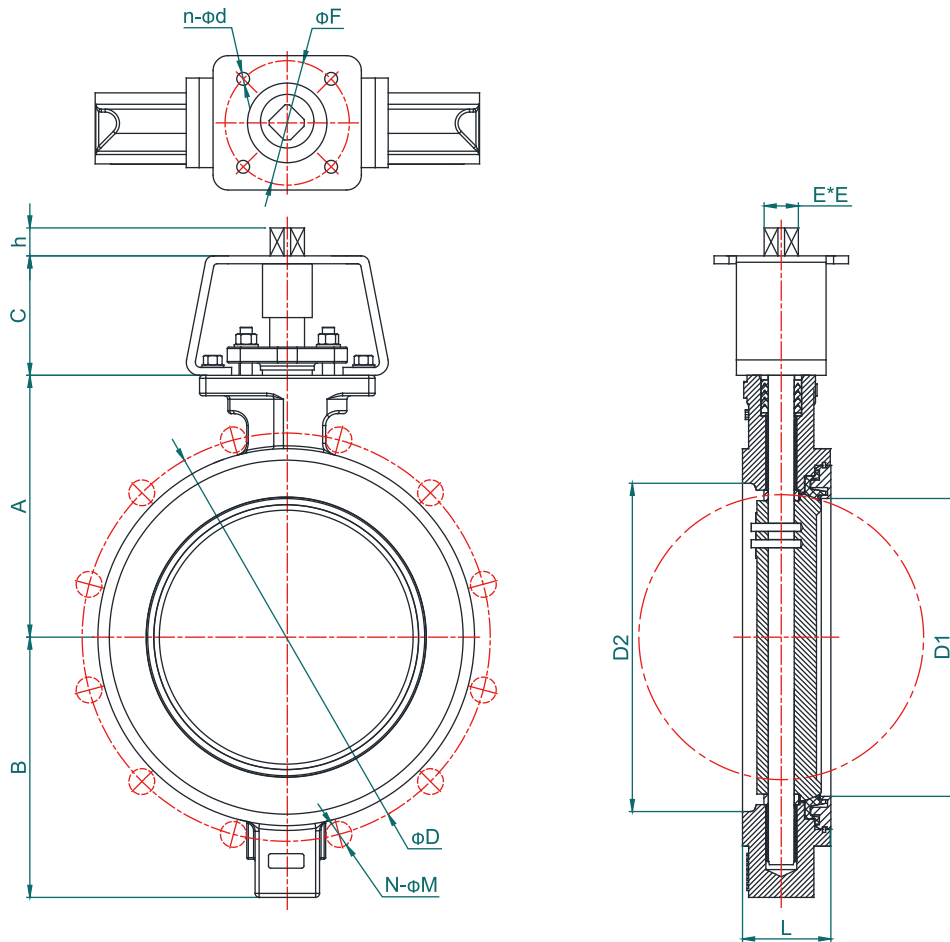

SIZE		A	B	C	D				N- ϕ M				D1	D2	E	h	F	n- ϕ d	L
DN	NPS				ANSI150	PN10	PN16	PN20	ANSI150	PN10	PN16	PN20							
50	2"	86	62	51	120.6	125	125	120.5	4- ϕ 19.1	4- ϕ 19	4- ϕ 19	4- ϕ 18	38	50	11	12	50	4- ϕ 8	43
65	2 1/2"	111	82	90	139.7	145	145	139.5	4- ϕ 19.1	4- ϕ 19	4- ϕ 19	4- ϕ 18	59	48	14	15	70	4- ϕ 10	49
80	3"	121	104	90	152.4	160	160	152.5	4- ϕ 19.1	8- ϕ 19	8- ϕ 19	4- ϕ 18	73	74	14	15	70	4- ϕ 10	49
100	4"	133	110	90	190.5	180	180	190.5	8- ϕ 19.1	8- ϕ 19	8- ϕ 19	8- ϕ 18	95	97	17	18	70	4- ϕ 10	54
125	5"	135	127	90	215.9	210	210	216	8- ϕ 22.2	8- ϕ 19	8- ϕ 19	8- ϕ 22	111	111	17	18	70	4- ϕ 10	57
150	6"	153	143	100	241.3	240	240	241.5	8- ϕ 22.2	8- ϕ 23	8- ϕ 23	8- ϕ 22	142	146	17	18	102+125	4- ϕ 11 / 4- ϕ 13	57
200	8"	188	172	100	298.5	295	295	298.5	8- ϕ 22.2	8- ϕ 23	12- ϕ 23	8- ϕ 22	188	194	17	18	102+125	4- ϕ 11 / 4- ϕ 13	64
250	10"	233	202	120	362	350	355	362	12- ϕ 25.4	12- ϕ 23	12- ϕ 28	12- ϕ 26	236	243	22	24	102+125	4- ϕ 11 / 4- ϕ 13	71
300	12"	265	238	120	431.8	400	410	432	12- ϕ 25.4	12- ϕ 23	12- ϕ 28	12- ϕ 26	282	289	22	24	102+125	4- ϕ 11 / 4- ϕ 13	81
350	14"	309	293	120	476.3	460	470	476	12- ϕ 28.6	16- ϕ 23	16- ϕ 28	12- ϕ 29.5	314	318	27	28	140	4- ϕ 17	92
400	16"	331	305	150	539.8	515	525	540	16- ϕ 28.6	16- ϕ 28	16- ϕ 31	16- ϕ 29.5	363	365	27	28	140	4- ϕ 17	102
450	18"	356	335	150	577.9	565	585	578	16- ϕ 31.8	20- ϕ 28	20- ϕ 31	16- ϕ 32.5	414	416	36	38	140	4- ϕ 17	114
500	20"	377	340	150	635	620	650	635	20- ϕ 31.8	20- ϕ 28	20- ϕ 34	20- ϕ 32.5	456	454	46	48	165	4- ϕ 22	127
600	24"	490	442	150	749.3	725	770	749.5	20- ϕ 34.9	20- ϕ 31	20- ϕ 37	20- ϕ 35.5	549	542	46	48	165	4- ϕ 22	154

Notes:

- 1) Bigger sizes available on request.
- 2) Please contact Coreline for available flange connections for all inquiries / orders.
- 3) Stem head (E, h) can be customized, contact Coreline for special requirement.

Dimensions - Lug type Class150, PN10/16/20

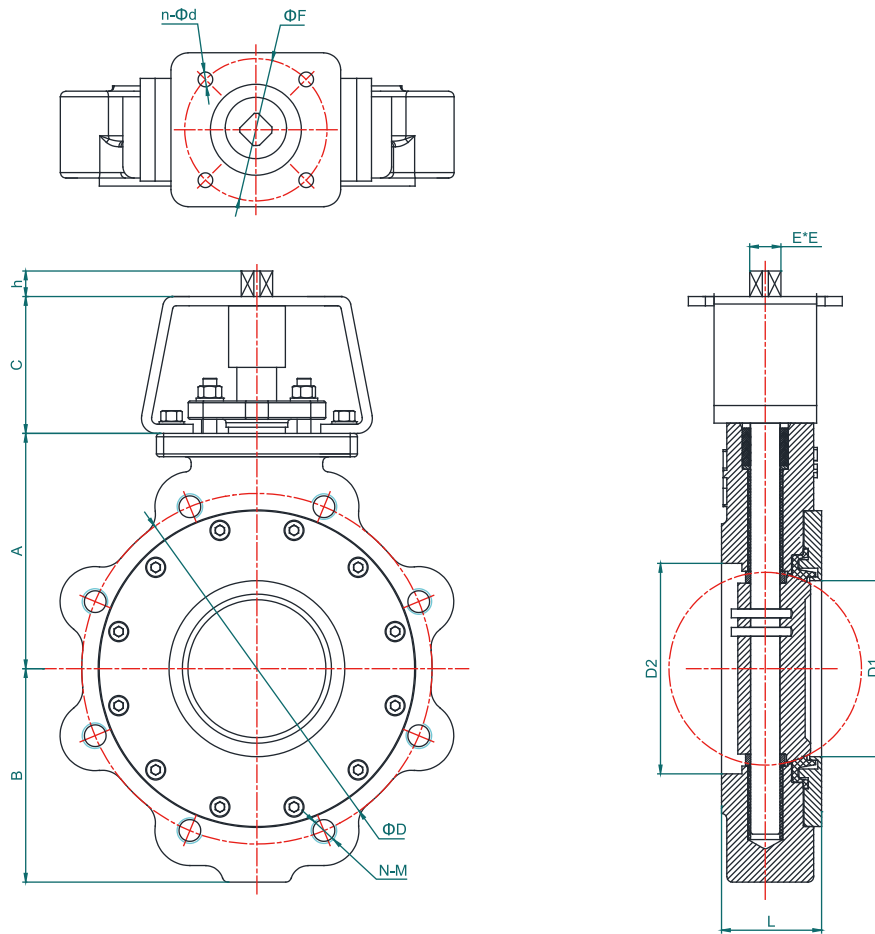

SIZE		A	B	C	D				N-M				D1	D2	E	h	F	n- Φd	L
DN	NPS				ANSI150	PN10	PN16	PN20	ANSI150	PN10	PN16	PN20							
50	2"	80	62	51	120.6	125	125	120.5	4-5/8"	4-M16	4-M16	4-M16	38	50	11	12	50	4- $\Phi 8$	43
65	2 1/2"	111	83	90	139.7	145	145	139.5	4-5/8"	8-M16	4-M16	4-M16	59	48	14	15	70	4- $\Phi 10$	49
80	3"	121	94	90	152.4	160	160	152.5	4-5/8"	8-M16	8-M16	4-M16	73	74	14	15	70	4- $\Phi 10$	49
100	4"	133	110	90	190.5	180	180	190.5	8-5/8"	8-M16	8-M16	8-M16	95	97	17	18	70	4- $\Phi 10$	54
125	5"	135	127	90	215.9	210	210	216	8-3/4"	8-M16	8-M16	8-M20	111	111	17	18	70	4- $\Phi 10$	57
150	6"	152	143	100	241.3	240	240	241.5	8-3/4"	8-M20	8-M20	8-M20	142	146	17	18	102+125	4- $\Phi 11$ / 4- $\Phi 13$	57
200	8"	187	172	100	298.5	295	295	298.5	8-3/4"	8-M20	12-M20	8-M20	188	194	17	18	102+125	4- $\Phi 11$ / 4- $\Phi 13$	64
250	10"	232	202	120	362	350	355	362	12-7/8"	12-M20	12-M24	12-M24	236	243	22	24	102+125	4- $\Phi 11$ / 4- $\Phi 13$	71
300	12"	260	238	120	431.8	400	410	432	12-7/8"	12-M20	12-M24	12-M24	282	289	22	24	102+125	4- $\Phi 11$ / 4- $\Phi 13$	81
350	14"	309	273	120	476.3	460	470	476	12-1"	16-M20	16-M24	12-M27	314	318	27	28	140	4- $\Phi 17$	92
400	16"	331	300	150	539.8	515	525	540	16-1"	16-M24	16-M27	16-M27	363	365	27	28	140	4- $\Phi 17$	102
450	18"	356	323	150	577.9	565	585	578	16-1 1/8"	20-M24	20-M24	16-M30	414	416	36	38	140	4- $\Phi 17$	114
500	20"	377	363	150	635	620	650	635	20-1 1/8"	20-M24	20-M30	20-M30	456	454	46	48	165	4- $\Phi 22$	127
600	24"	489	454	150	749.3	725	770	749.5	20-1 1/4"	20-M27	20-M33	20-M30	549	542	46	48	165	4- $\Phi 22$	154

Notes:

- 1) Bigger sizes available on request.
- 2) Please contact Coreline for available flange connections for all inquiries / orders.
- 3) Stem head (E, h) can be customized, contact Coreline for special requirement.

Dimensions - Wafer type Class300, PN25/40

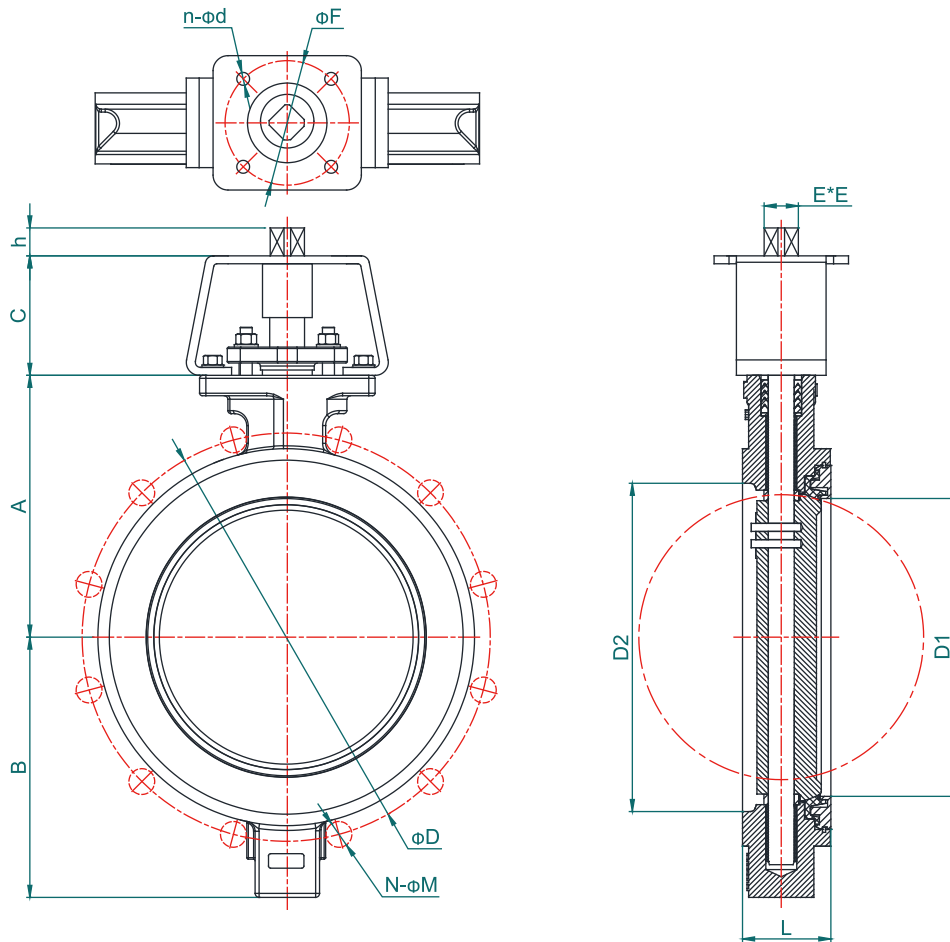

SIZE		A	B	C	D			N-φM			D1	D2	E	h	F	n-φd	L
DN	NPS				ANSI300	PN25	PN40	ANSI300	PN25	PN40							
50	2"	86	62	51	127	125	125	8-φ19.1	4-φ18	4-φ18	38	50	14	15	50	4-φ8	43
65	2 1/2"	111	82	90	149.2	145	145	8-φ22.2	8-φ18	8-φ18	59	48	14	15	70	4-φ10	49
80	3"	121	104	90	168.3	160	160	8-φ22.2	8-φ18	8-φ18	73	74	14	15	70	4-φ10	49
100	4"	133	116	90	184.2	190	190	8-φ22.2	8-φ22	8-φ22	95	97	17	18	70	4-φ10	54
125	5"	153	118	90	200	220	220	8-φ22.2	8-φ26	8-φ26	111	111	17	18	70	4-φ10	59
150	6"	175	153	100	235	250	250	12-φ22.2	8-φ26	8-φ26	142	146	17	18	102+125	4-φ11 / 4-φ13	59
200	8"	213	180	120	269.9	310	320	12-φ22.2	12-φ26	12-φ30	188	194	22	24	102+125	4-φ11 / 4-φ13	73
250	10"	254	231	120	330.2	370	385	16-φ25.4	12-φ30	12-φ33	236	243	27	28	102+125	4-φ11 / 4-φ13	83
300	12"	283	279	120	387.4	430	450	16-φ28.6	16-φ30	16-φ33	282	289	27	28	140	4-φ17	92
350	14"	325	293	150	450.8	490	510	20-φ31.8	16-φ33	16-φ36	314	318	36	38	140	4-φ17	117
400	16"	351	335	150	514.4	550	585	20-φ34.9	16-φ36	16-φ39	363	365	46	48	165	4-φ22	133
450	18"	425	367	150	628.6	600	610	24-φ34.9	20-φ36	20-φ39	414	416	46	48	165	4-φ22	149
500	20"	447	435	150	685.8	660	670	24-φ34.9	20-φ36	20-φ42	456	454	46	48	165	4-φ22	159
600	24"	501	483	150	812.8	770	795	24-φ41.3	20-φ39	20-φ48	549	542	46	48	254	8-φ18	181

Notes:

- 1) Bigger sizes available on request.
- 2) Please contact Coreline for available flange connections for all inquiries / orders.
- 3) Stem head (E, h) can be customized, contact Coreline for special requirement.

Bracket and coupling, torque values

Torque values

SIZE		Torque [Nm] - Class150, PN10/16/20			Torque [Nm] - Class300, PN25/40					
DN	INCH	6.9bar	13.8bar	19.7bar	20.7bar	27.6bar	34.5bar	41.4bar	48.3bar	51bar
DN50	2"	30	31	34	44	47	53	59	62	62
DN65	2 ½"	38	40	43	44	47	53	59	62	62
DN80	3"	44	48	51	55	60	66	72	78	81
DN100	4"	61	77	75	91	103	114	127	138	140
DN125	5"	85	99	112	150	172	196	220	242	251
DN150	6"	126	147	150	209	244	278	314	348	362
DN200	8"	213	251	270	407	478	549	621	692	721
DN250	10"	289	356	400	624	744	863	983	1103	1110
DN300	12"	377	507	580	867	1027	1187	1346	1506	1570
DN350	14"	638	889	1050	1452	1784	2115	2447	2779	2911
DN400	16"	816	1139	1413	1742	2136	2530	2923	3315	3420
DN450	18"	1061	1487	1850	22664	2753	3276	3751	4250	4449
DN500	20"	1427	2010	2504	3008	3695	4380	5067	5752	6026
DN600	24"	2175	3099	3878	4070	4992	5888	6836	7758	8127

Note: The torque values are including 30% safety.

Cv values

SIZE		Opening angle - Class150, PN10/16/20 valves		Opening angle - Class300, PN25/40 valves	
DN	INCH	60°	90°	60°	90°
50	2"	25	50	25	50
65	2 ½"	39	78	39	78
80	3"	83	165	83	165
100	4"	200	400	200	400
125	5"	325	650	325	650
150	6"	525	1050	500	1050
200	8"	1100	2200	900	1800
250	10"	1650	3300	1575	3150
300	12"	2550	5100	2375	4750
350	14"	2900	5800	2600	5200
400	16"	4000	8000	3450	6900
450	18"	5250	10500	4650	9300
500	20"	7000	14000	5650	11300
600	24"	10800	21600	9250	18500

Note: Converting between Flow Coefficient Cv and Flow Factor Kv:

$$Cv = 1.156 \cdot Kv; Kv = 0.864 Cv.$$

Cv curves

Cv curve - Class150, PN10/16/20 valves

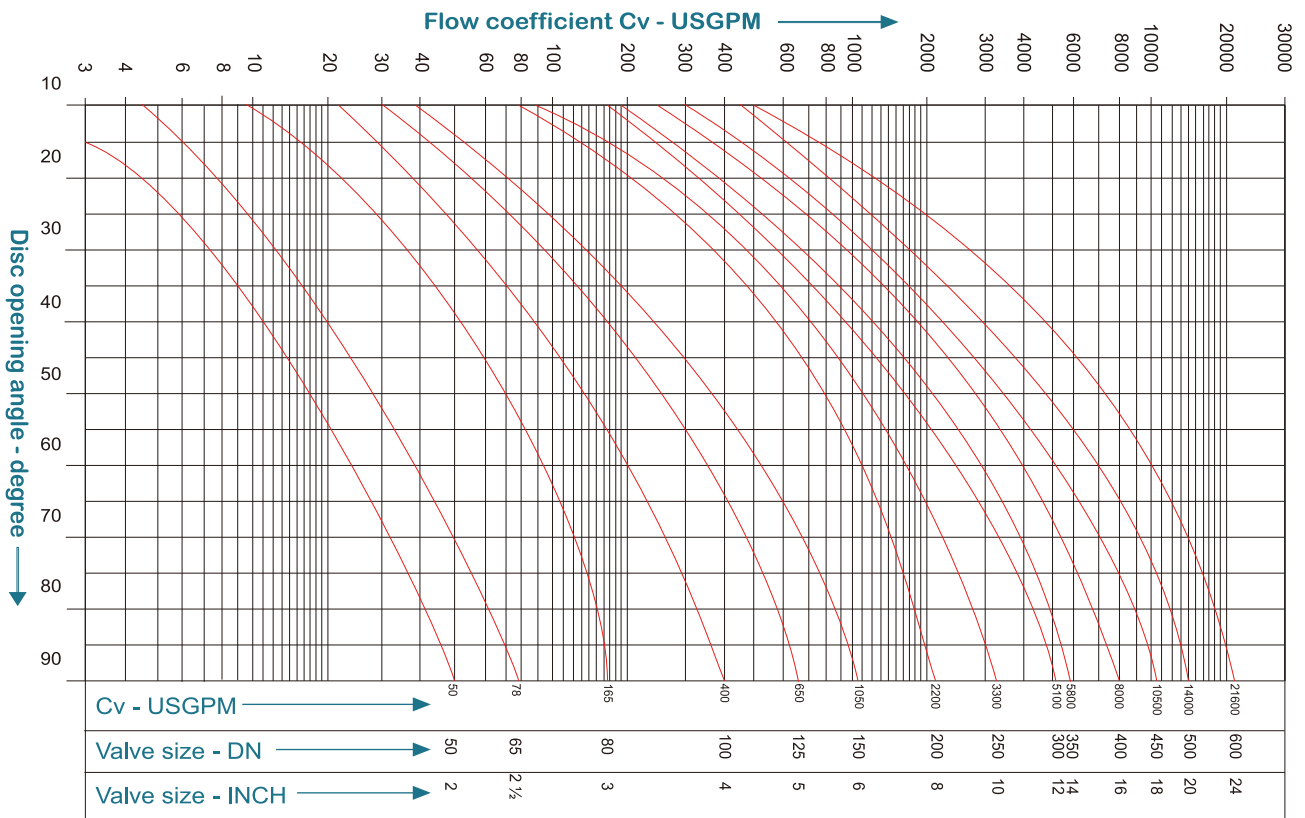

Cv curve - Class300, PN25/40 valves

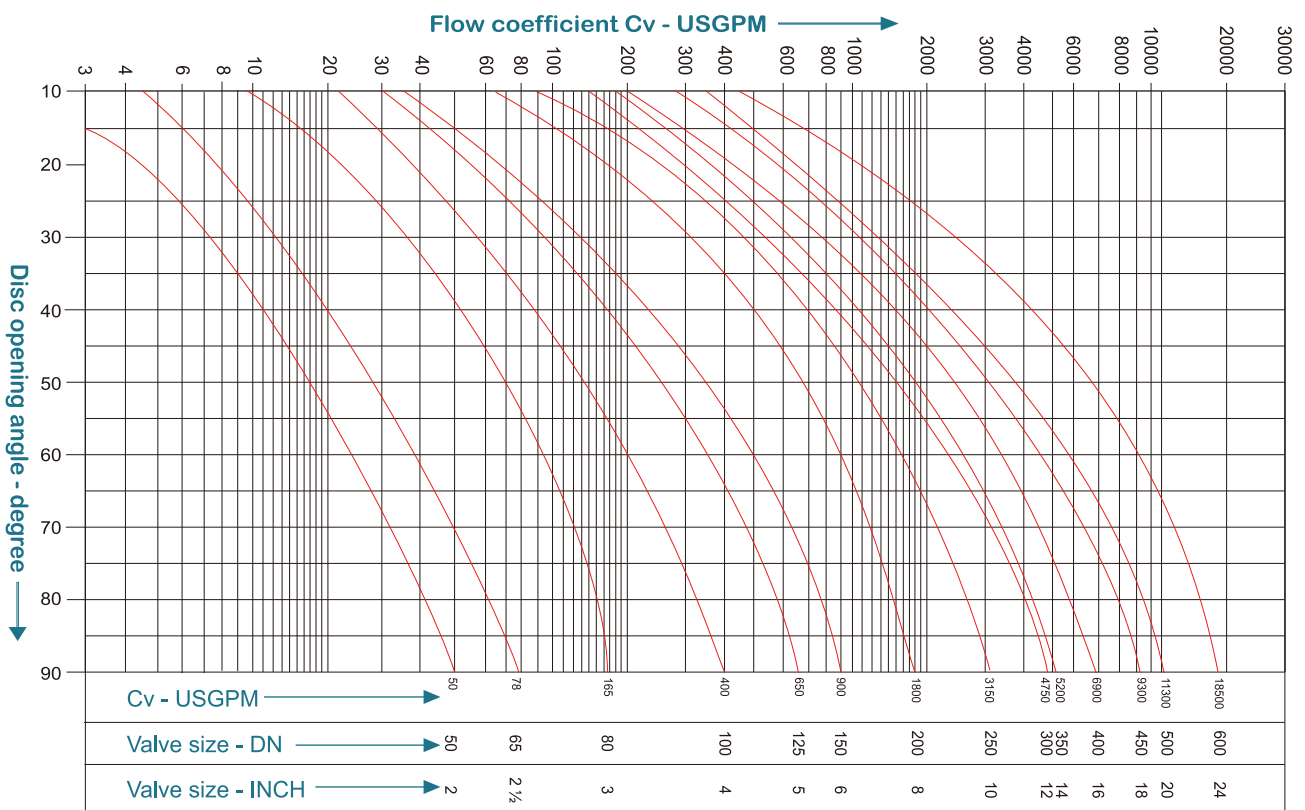

Note: Converting between Flow Coefficient Cv and Flow Factor Kv:

$$Cv = 1.156 * Kv; Kv = 0.864 Cv.$$

Technical data

Body rating [bar] - Class150, PN10/16/20

Temp. / °C	WCB	SS316	Alloy 20	Monel
-29 to 38	19.6	19	15.9	15.9
100	17.7	16.2	13.5	13.7
150	15.8	14.8	12.3	13.1
200	13.8	13.7	11.3	12.8
250	12.1	12.1	10.4	11.9
Test pressure / bar	30	29	24	24

Body rating [bar] - Class300, PN25/40

Temp. / °C	WCB	SS316	Alloy 20	Monel
-29 to 38	51.1	49.6	41.4	41.3
100	46.6	42.2	35.3	36.2
150	45.1	38.5	32	34.1
200	43.8	35.7	29.4	33.1
250	41.9	33.4	27.2	32.8
Test pressure / bar	77	75	63	63

Seat rating

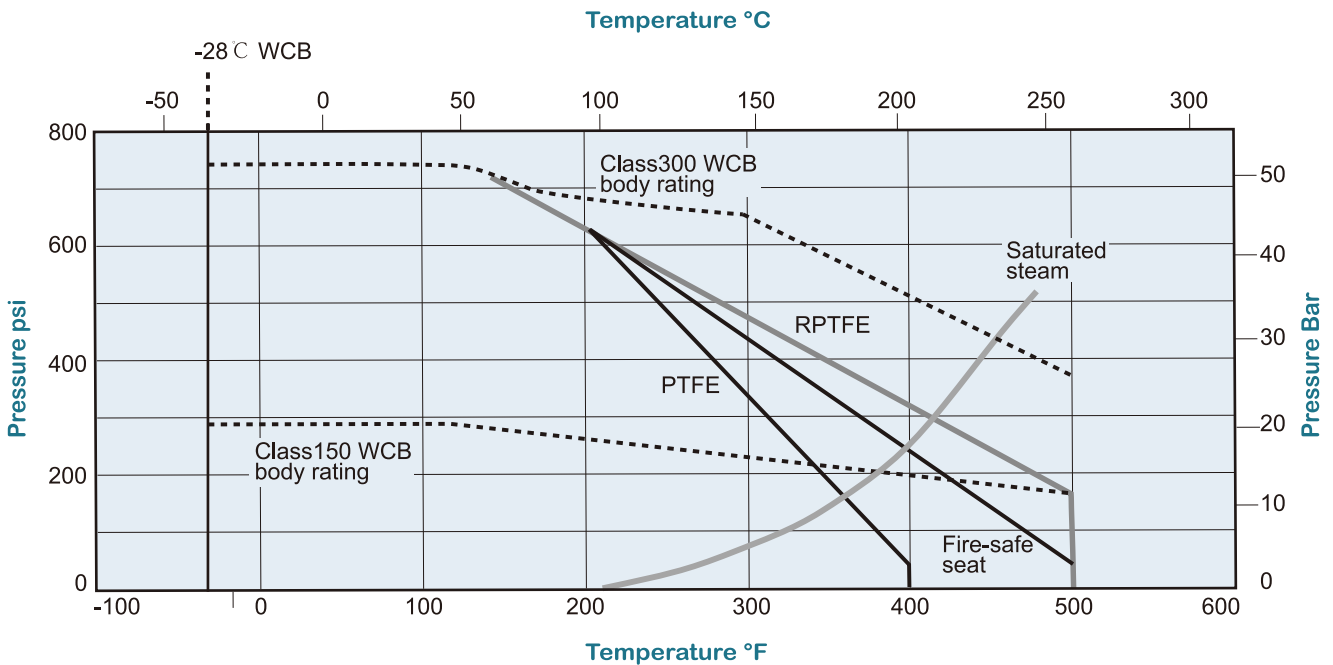

Coreline

CORELINE LTD.

Add: No.4 Wangjiang Road, Muqiao Town, Zhengpugang New District, 238200 Hexian, Ma'anshan City, Anhui Province, China

The contents of this catalogue are confidential and proprietary to Coreline, we reserve the right to change the specifications without any notice.

Http: // www.coreline.dk

E-mail : mail@coreline.cn