

2pc PTFE lined butterfly valve

Fig.225 : Wafer

Fig.226 : Lug



www.coreline.dk

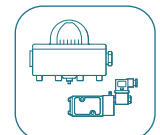
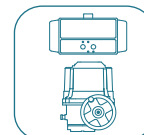
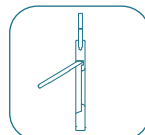
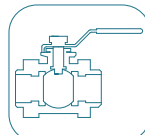
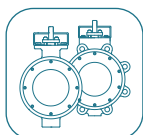

General information

Specifications

Connection:	Fig.225 wafer, Fig.226 lug
Nominal diameter:	DN40-DN800 (Bigger sizes available on request)
Working pressure:	DN40-DN150 ≤ 16bar DN200-DN350 ≤ 10bar DN400-DN450 ≤ 8bar DN500 ≤ 6bar DN600 ≤ 4bar DN700-DN800 = 1bar
Flange:	EN1092 PN10, PN16. ASME B16.5 Class150
Face to face:	EN558 Series 20, API609 Table 1
Top flange:	ISO5211
Body:	Ductile iron, carbon steel, stainless steel
Disc:	PTFE, PFA, SS304, SS316, SS316L, EN 1.4410, EN 1.4529
Seat:	PTFE + EPDM backup: T≤110 °C PTFE + FPM backup: T≤130 °C PTFE + Silicone backup: T≤160 °C



CE approval



ATEX approval



EU1935/2004: EU Food Contact Regulations



FDA: U.S. Food and Drug Administration

Index

page 3+4	Design features
page 5	Material part list - Valve with PTFE + rubber backup seat
page 6	Material part list - Valve with PTFE + silicone backup seat
page 7	Fig.225 Dimensions
page 8	Fig.226 Dimensions
page 9	Technical data
page 10	Valve with hand lever
page 11	Valve with gear box
page 12	Pneumatic actuator sizing

Design features

Specifications

- 2-pcs body construction makes it possible to replace seats.
- EPDM or FPM energized backup behind PTFE seat ensures perfect tightness - ISO5208 Rate A.
- Removalbe Silicone backup behind PTFE seat provides reliable sealing as well as wider range of working temperature.
- Suitable for a variety of applications: water and sewage, chemical and petrochemical industry, pharmaceutical/sanitary industry, food/beverage, paper industry, colouring, varnish, dyeing industries etc.



Design features

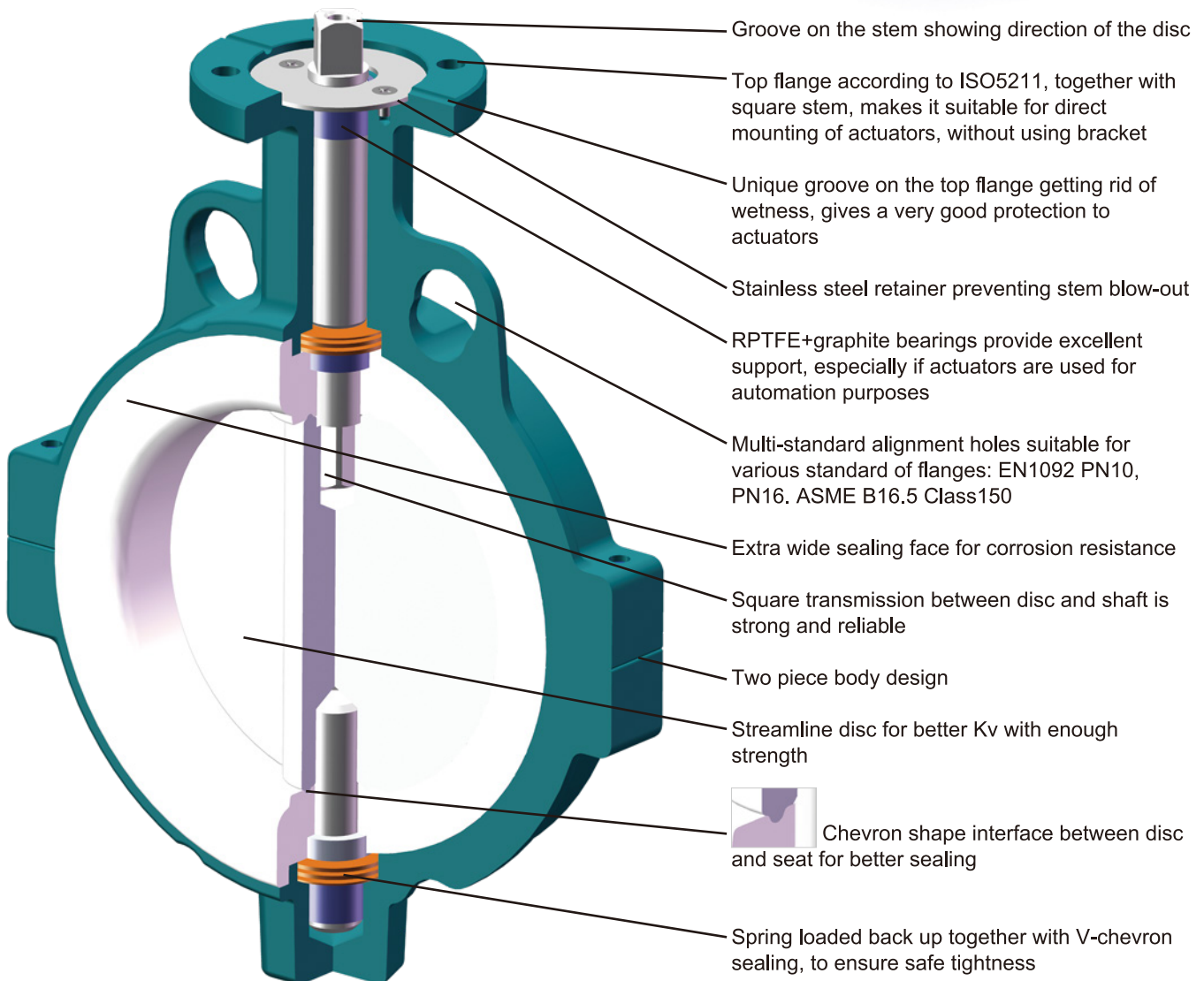

Design features

Integrated seat - PTFE with EPDM/FPM backup

PTFE with EPDM backup seat: Temperature $\leq 110^{\circ}\text{C}$.

PTFE with FPM backup seat: Temperature $\leq 130^{\circ}\text{C}$.

PTFE seat is resistant to chemically toxic and high corrosion, but we specially recommend you to use PTFE with FPM backup or PTFE with silicone bar seat if the media is oil or similar.

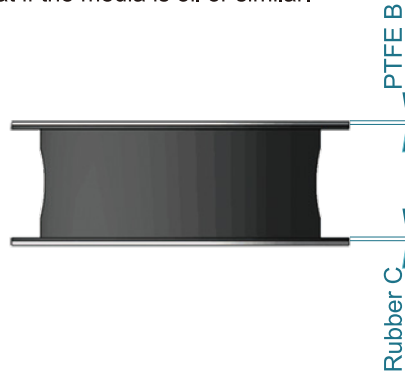

Below you can find PTFE and rubber thickness of the integrated seat.

Size	PTFE thickness B [mm]	Rubber thickness C [mm]	Size	PTFE thickness B [mm]	Rubber thickness C [mm]
DN50	2	2	DN250	2.5	3
DN65	2	2	DN300	2.5	3
DN80	2	2	DN350	2.8	3
DN100	2.3	2.2	DN400	3	3
DN125	2.4	2.6	DN450	3	3
DN150	2.4	2.6	DN500	3.5	3.5
DN200	2.4	2.6	DN600	3.5	3.5

Split seat - PTFE with Silicone backup

PTFE with Silicone backup seat: Temperature $\leq 160^{\circ}\text{C}$.

PTFE and Silicone can be separated from each other. The thicker PTFE layer can maximizly reduce the media's penetration.



Size	PTFE thickness minimum [mm]	Size	PTFE thickness minimum [mm]
DN50	3.5	DN250	4
DN65	3.5	DN300	4.5
DN80	3.5	DN350	5
DN100	3.5	DN400	5
DN125	3.7	DN450	5
DN150	3.7	DN500	7~8
DN200	4	DN600	7~8

Material part list - Valve with PTFE + rubber backup seat

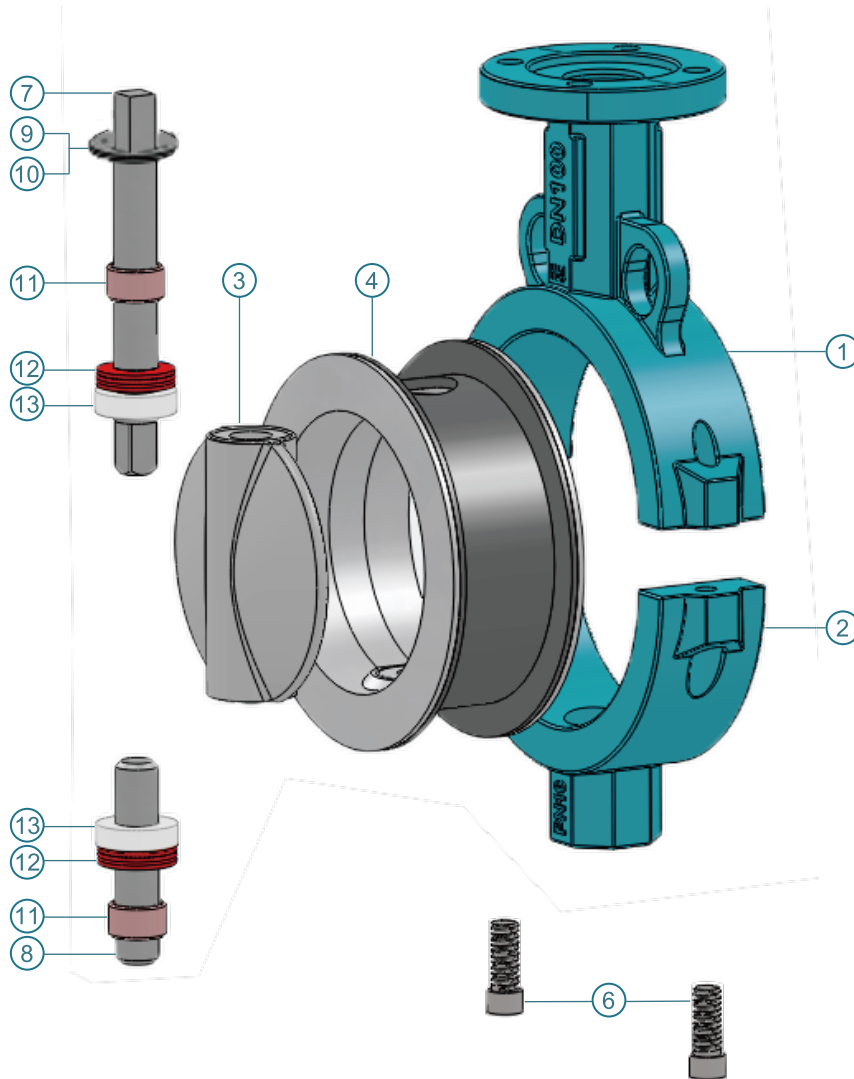

No.	Part name	Material	Specification	No.	Part name	Material
1/2	Body	Ductile iron	EN1563 JS1030	6	Body bolt	SS304
		Carbon steel	ASTM A216 WCB	7/8	Stem	SS420
		Stainless steel	ASTM A351 CF8M	9	Preventing plate	SS304
3	Disc	Stainless steel	ASTM A351 CF8	10	Screw	SS304
			ASTM A351 CF8M	11	Bearing	RPTFE with graphite
		Alloy steel	1.4469 (SAF2507)	12	Spring	Spring steel
			1.4462 (SAF2205)	13	Packing ring	PTFE
		PTFE	PTFE coated CF8M			
		PFA	PFA coated CF8M			
4	Seat	PTFE with EPDM backup	-20°C~+110°C			
		PTFE with FPM backup	-20°C~+130°C			

Material part list - Valve with PTFE + silicone backup seat

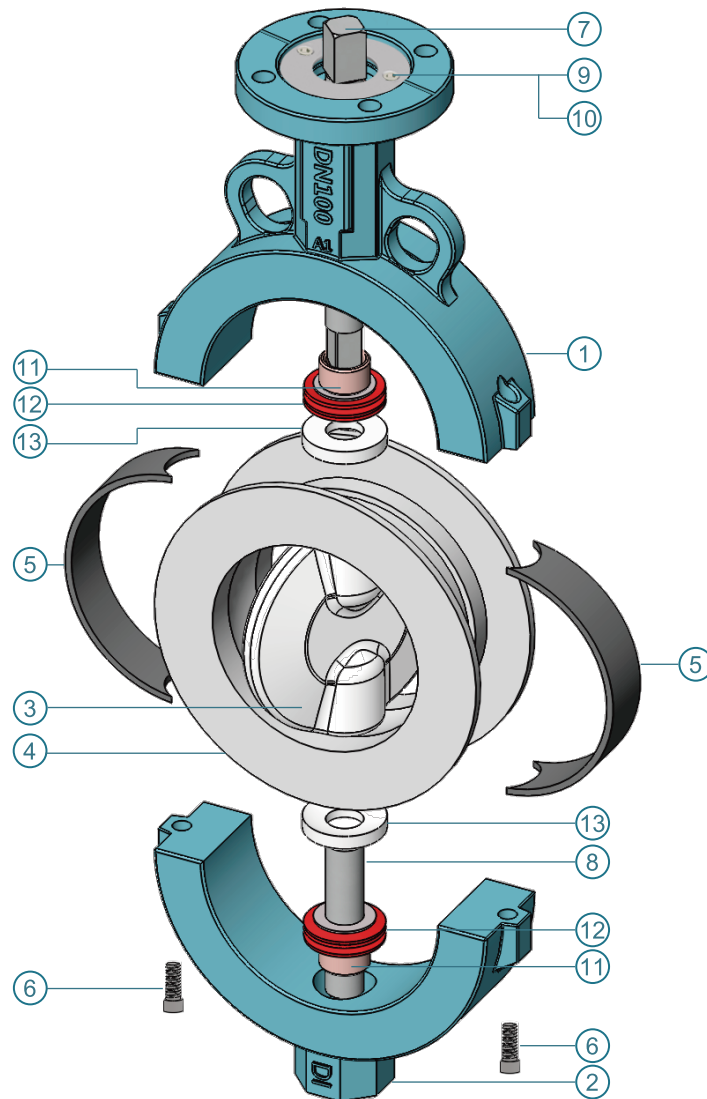

No.	Part name	Material	Specification	No.	Part name	Material
1/2	Body	Ductile iron	EN1563 JS1030	6	Body bolt	SS304
		Carbon steel	ASTM A216 WCB	7/8	Stem	SS420
		Stainless steel	ASTM A351 CF8M	9	Preventing plate	SS304
3	Disc	Stainless steel	ASTM A351 CF8	10	Screw	SS304
			ASTM A351 CF8M	11	Bearing	RPTFE with graphite
		Alloy steel	1.4469 (SAF2507)	12	Spring	Spring steel
			1.4462 (SAF2205)	13	Packing ring	PTFE
		PTFE	PTFE coated CF8M			
		PFA	PFA coated CF8M			
4	Seat	PTFE				
5	Rubber back	Silicone	-20°C~+160°C			

Dimensions - Fig.225

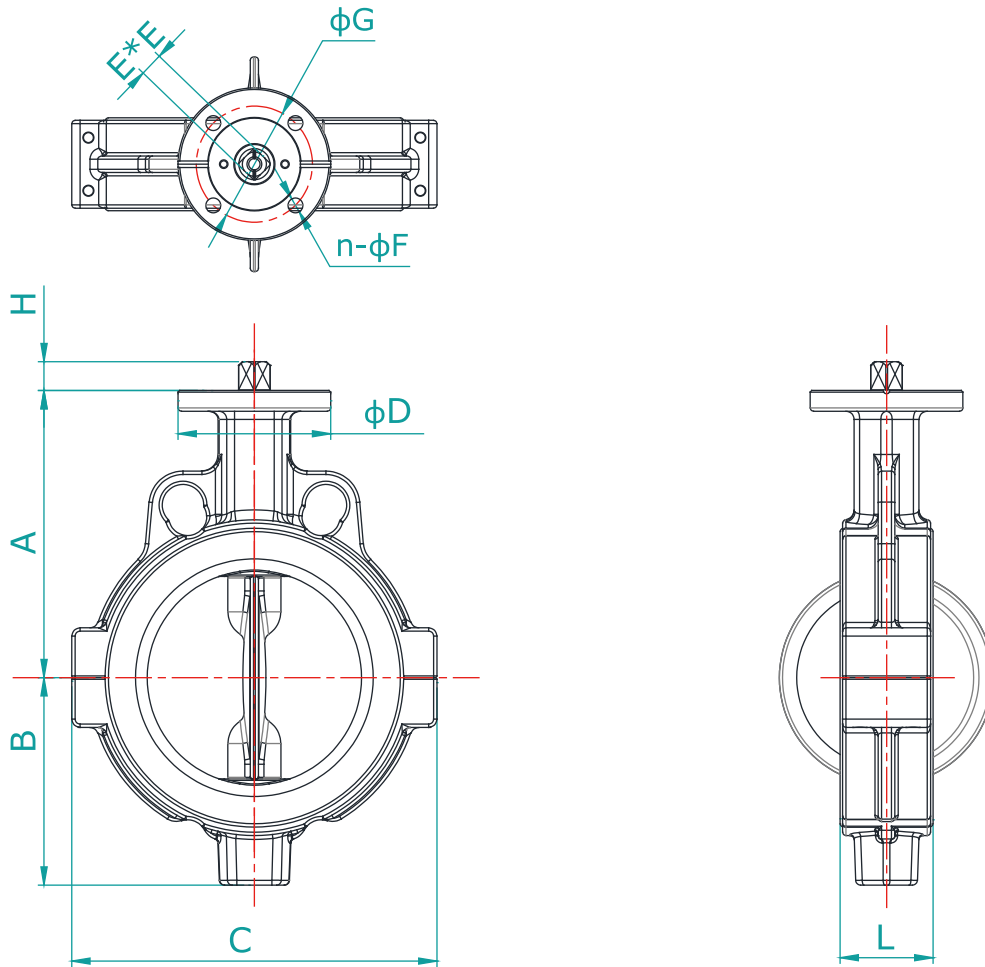

Dimensions - Fig.225

DN	INCH	A	B	C	D	E	n	F	G	H	L	Weight [kg]
50	2"	136	62	112	65	11	4	7	50	13.5	47	2
65	2 1/2"	138	70	126	65	11	4	7	50	13.5	50	2.5
80	3"	140	78	142	65	11	4	7	50	13.5	50	3
100	4"	158	105	168	90	14	4	10	70	17.5	55.5	4
125	5"	180	122	240	90	14	4	10	70	17.5	59	6
150	6"	186	134	265	90	17	4	10	70	18.5	59	7
200	8"	234	165	320	125	22	4	14	102	24.5	63	13
250	10"	273	194	385	125	22	4	14	102	24.5	73	20
300	12"	302	224	450	125	27	4	14	102	30.5	81	30
350	14"	320	260	500	125	27	4	14	102	30.5	81	56
400	16"	408	298	585	175	27	4	18	140	30.5	92	80
450	18"	422	315	616	175	36	4	18	140	39	116.5	120
500	20"	480	356	685	210	36	4	22	165	39	130	160
600	24"	562	440	818	210	46	4	22	165	49	157	200
700	28"	625	520	910	300	$\phi 63.1$	8	18	254	90	165	270
800	32"	672	590	1050	300	$\phi 63.1$	8	18	254	90	188	370

Dimensions - Fig.226

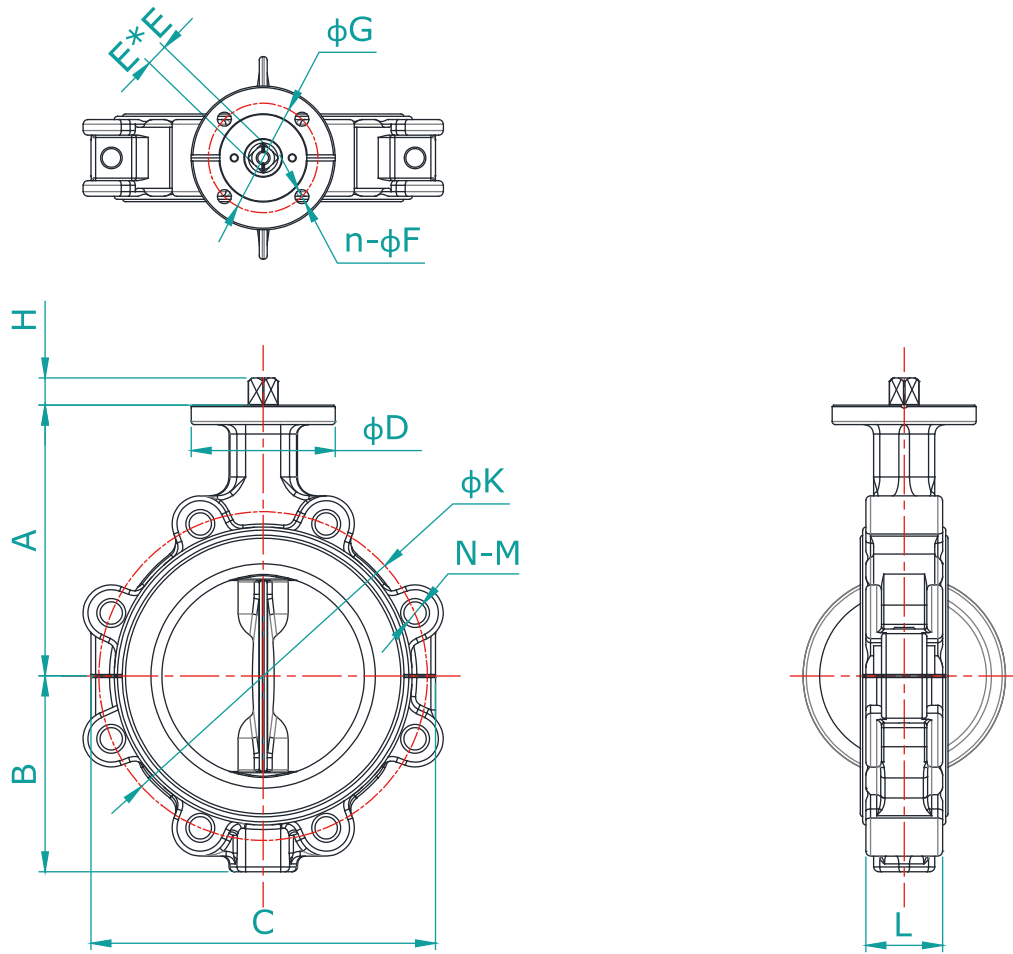

Dimensions - Fig.226

DN	INCH	A	B	C	D	E	n	F	G	H	L	ANSI150		DIN PN 10		DIN PN 16		Weight [kg]
												ϕK	N-M	ϕK	N-M	ϕK	N-M	
50	2"	136	62	153	65	11	4	7	50	13.5	47	120.5	4-5/8"	125.0	4-M16	125.0	4-M16	3
65	2 1/2"	138	70	155	65	11	4	7	50	13.5	50	139.5	4-5/8"	145.0	4-M16	145.0	4-M16	3.5
80	3"	140	78	180	65	11	4	7	50	13.5	50	152.5	4-5/8"	160.0	8-M16	160.0	8-M16	4.3
100	4"	158	105	205	90	14	4	10	70	17.5	55.5	190.5	8-5/8"	180.0	8-M16	180.0	8-M16	6.8
125	5"	180	122	240	90	14	4	10	70	17.5	59	216	8-3/4"	210	8-M16	210	8-M16	8
150	6"	186	134	265	90	17	4	10	70	18.5	59	241.5	8-3/4"	240.0	8-M20	240.0	8-M20	9
200	8"	234	165	320	125	22	4	14	102	24.5	63	298.5	8-3/4"	295.0	8-M20	295.0	12-M20	15
250	10"	273	194	385	125	22	4	14	102	24.5	73	362	12-7/8"	350	12-M20	355	12-M24	23
300	12"	302	224	450	125	27	4	14	102	30.5	81	432	12-7/8"	400	12-M20	410	12-M24	33
350	14"	320	260	500	125	27	4	14	102	30.5	81	476.3	12-1"	460.0	16-M20	470.0	16-M24	66
400	16"	408	298	585	175	27	4	18	140	30.5	92	539.9	16-1"	515.0	16-M24	525.0	16-M27	88
450	18"	422	315	616	175	36	4	18	140	39	116.5	577.9	16-1 1/8"	565.0	20-M24	585.0	20-M27	150
500	20"	480	356	685	210	36	4	22	165	39	130	635	20-1 1/8"	620	20-M24	650	20-M30	200
600	24"	562	440	818	210	46	4	22	165	49	157	749.3	20-1 1/4"	725.0	20-M27	770.0	20-M33	260
700	28"	625	520	910	300	$\phi 63.1$	8	18	254	90	165	863.6	28-1 1/4"	840.0	24-M27	840.0	24-M33	300
800	32"	672	590	1050	300	$\phi 63.1$	8	18	254	90	188	977.9	28-1 1/2"	950.0	24-M30	950.0	24-M36	420

Technical data

Torque - Nm

DN	INCH	1) Valve torque [Nm]	2) MAST Value [Nm]		
			SS420	SS431	17-4PH
50	2"	18-25	58	77	150
65	2 1/2"	20-27	58	77	150
80	3"	40-48	58	77	150
100	4"	50-65	124	165	321
125	5"	80-110	124	165	321
150	6"	110-165	213	283	553
200	8"	250-350	461	614	1198
250	10"	350-400	461	614	1198
300	12"	460-580	852	1136	2214
350	14"	800-1100	1478	1970	3843
400	16"	1100-1330	1478	1970	3843
450	18"	1700-2300	2528	3370	6574
500	20"	2300-2900	2528	3370	6574
600	24"	2500-3250	4212	5616	10950
700	28"	3500-4500	6114	8152	15896
800	32"	5500-6500	6114	8152	15896

1) Torques above are not including safety factor and are measured without load under room temperature.

Add a safety factor 1.2~1.3 for sizing or consult Coreline under certain working conditions.

2) MAST: Maximum Allowable Stem Torque. Please contact Coreline for MAST values for other materials.

Kv value - m³/h at 1bar ΔP

DN	INCH	Opening angle - Full lined butterfly valve Kv [M ³ /H at 1Bar ΔP]								
		10°	20°	30°	40°	50°	60°	70°	80°	90°
50	2"	0.1	3.9	11	21	39	52	78	104	113
65	2 1/2"	0.2	5.6	18	33	57	78	122	174	182
80	3"	0.3	8.7	20	35	61	100	156	238	260
100	4"	0.4	15	32	65	117	199	303	450	520
125	5"	0.7	24	52	113	200	334	537	796	866
150	6"	1.6	35	83	174	308	520	822	1212	1298
200	8"	2.6	74	163	347	619	1039	1644	2431	2596
250	10"	3.5	130	270	592	1085	1713	2769	4180	4499
300	12"	4.3	200	403	866	1566	2596	4326	6488	7077
350	14"	5.2	260	606	1298	2385	3893	6229	8660	10005
400	16"	6.9	390	834	1818	3084	5364	8218	12847	14004

DN	INCH	Opening angle - Half lined butterfly valve Kv [M ³ /H at 1Bar ΔP]								
		10°	20°	30°	40°	50°	60°	70°	80°	90°
50	2"	0.9	4	12	23	43	58	86	115	124
65	2 1/2"	0.9	6	20	37	62	86	134	191	200
80	3"	1.7	10	21	39	67	110	172	262	286
100	4"	2.6	16	35	72	129	219	334	495	571
125	5"	3.5	27	58	124	220	367	590	876	952
150	6"	4.3	38	91	192	339	571	904	1333	1428
200	8"	6.9	81	179	382	681	1142	1808	2674	2855
250	10"	8.7	143	297	651	1194	1885	3045	4597	4949
300	12"	14	219	443	953	1723	2855	4758	7137	7784
350	14"	16	286	667	1428	2623	4283	6852	9526	11005
400	16"	24	428	917	2000	3392	5900	9040	14131	15404

Note:

Fully lined butterfly valve - PTFE/PFA lined seat + PTFE/PFA lined disc.

Half lined butterfly valve - PTFE/PFA lined seat + Stainless/alloy disc.

Valve with hand lever

Fig.500 Aluminium hand lever

- Excellent design and comfortable operating 90° in 10 positions. The lever is fixed by screw on top of stem to avoid the lever getting loose by operation or vibrations. For safety, the hand lever can be locked in position by bolt/nut or a locker.
- Material is AL-Si alloy, which has better performance than Al-Mg and Al-Zn alloy.
- Electrophoresed surface treatment, which has stronger adhesion than traditional painting and much better resistance to corrosion.

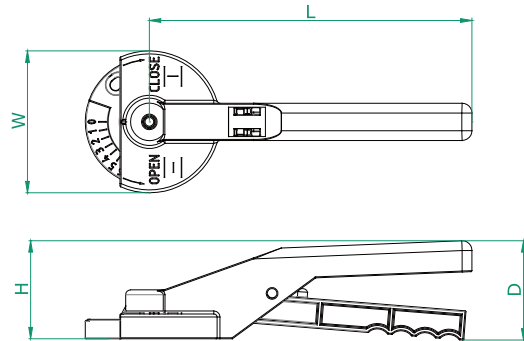

Valve Size	D	H	L	W	Stem drive	[kg]
DN40-DN80	56	65	195	74	F05 - 11×11	0.28
DN100-DN125	78	82	269	101	F07 - 14×14	0.63

Fig.503 GGG40 and CF8M hand lever

- GGG40 and CF8M hand lever have the same shape and share the same angle plate and locker.
- GGG40 hand lever has strong electrophoresed surface treatment. CF8M hand lever is with precise casting which has very smooth surface.
- Locker and plate in stainless steel SS316 and spring in SS321.
- Good design and comfortable operating 90° in 10 positions, but also adjustable screw to choose any position for regulation.
- The lever is fixed by screw on top of stem and not by side of stem, to avoid the lever getting loose by operation or vibrations. For safety, the hand lever can be locked in position by bolt/nut or a padlock.

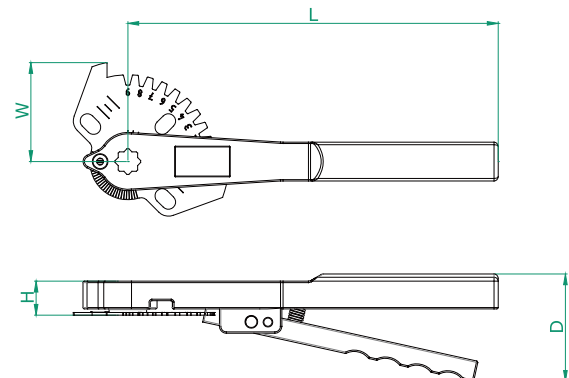

Valve Size	D	H	L	W	Stem drive	[kg]
DN40-DN80	53	23	195	60	F05 - 11×11	0.8
DN100-DN125	77	30	267	73	F07 - 14×14	1.2

Valve with gear box

Fig.520 Aluminium gear box

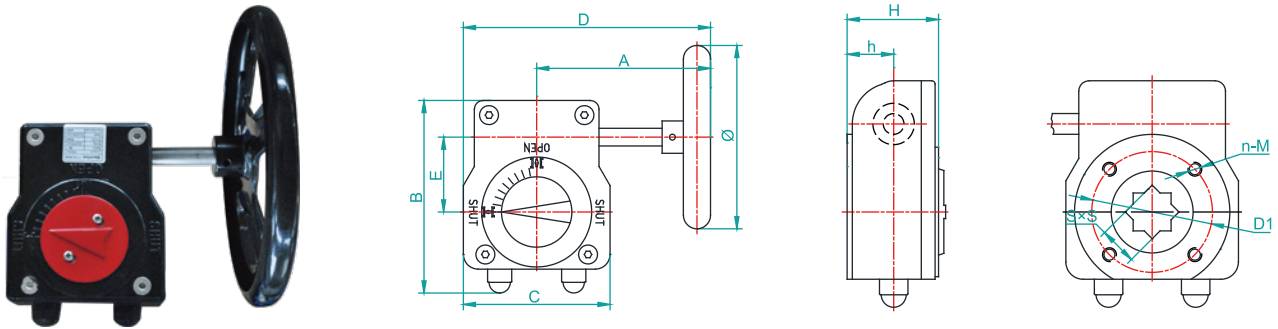

Fig.521 Cast iron, CF8M gear box

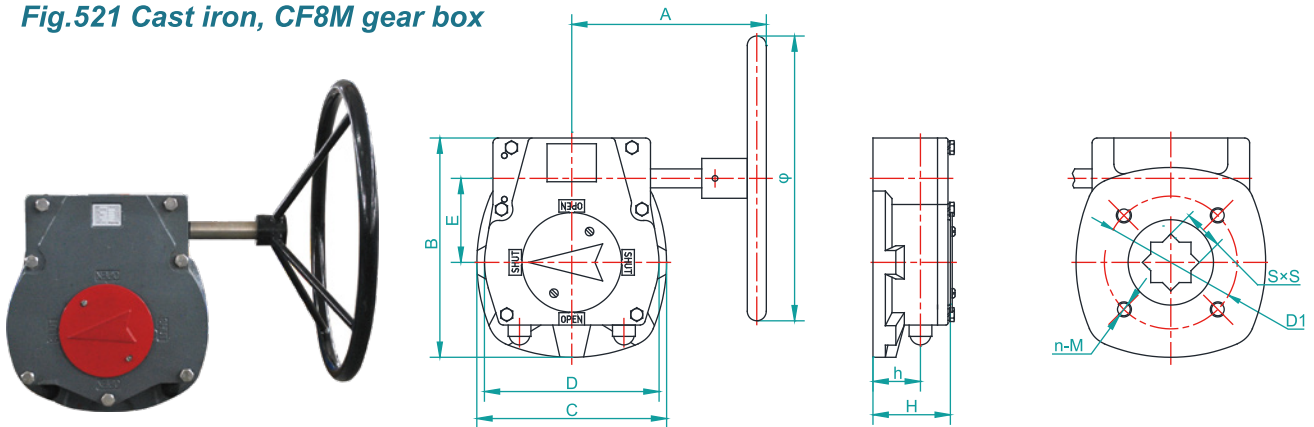
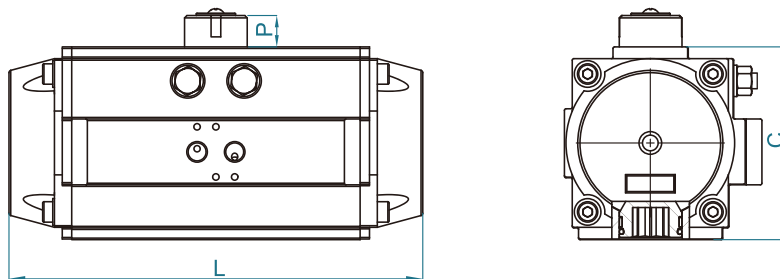

Fig.225/226		Gear Box																
Size	Torque [Nm]	Model	Output [Nm]	Ratio	Input [Nm]	A	B	C	D	E	Φ	h	H	D1	n-M	S	[kg]	Material
DN50	18-25	520-10	150	40:1	18.5	99	98	80	139	42.5	100	26	48	50+70	4-M6/4-M8	11 x 11	1.45	Housing: Aluminium/ CF8M Input shaft: SS410/ SS304/SS316 Gear: Ductile iron Alu-Bronze
DN65	20-27																	
DN80	40-48																	
DN100	50-65	520-15	250	37:1	34	115	115	100	165	50	120	27	54	70	4-M8	14 x 14	1.9	
DN125	80-110																	
DN150	110-165																17 x 17	
DN200	250-350	520-50	750	45:1	83	220	155	146	293	60	300	38	71	102	4-M10	22 x 22	5.2	
DN250	350-400																	
DN300	460-580																27 x 27	
DN350	800-1100	521-M14	1800	60:1	110	277	231	184	200	89	300	50	81	102	4-M10	27 x 27	14	
DN400	1100-1330													140	4-M16			
DN450	1700-2300	521-M15	3400	68:1	165	357	296	248	252	123	400	50	91	140	4-M16	36 x 36	32	
DN500	2300-2900													165	4-M20			
DN600	2500-3250													521-M16	4400			88:1
DN700	3500-4500	521-M36	8000	210:1	180	448	380	286	310	138	500	73	130	254	8-M16	ϕ 63.1	66	Housing: Cast iron/ CF8/CF8M Worm shaft: SS410/ SS304/SS316 Gear: Ductile iron/ Alu-Bronze
DN800	5500-6500																	

Pneumatic actuator sizing - 6bar air supply



Sizing - Fig.540 Air/air (Double acting)

Fig.225/226				Sizing - Fig.540 Double acting - Air supply 6bar						
DN	INCH	ISO5211	Torque /Nm	Size	ISO5211	Output torque /Nm	C [mm]	P [mm]	L [mm]	[kg]
50	2"	F05	18-25	65	F03+F05,F04	43.9	89	20	189	1.97
65	2 ½"	F05	20-27	65	F03+F05,F04	43.9	89	20	189	1.97
80	3"	F05	40-48	75	F05+F07	68.2	100	20	210	2.93
100	4"	F07	50-65	75	F05+F07	68.2	100	20	210	2.93
125	5"	F07	80-110	85	F05+F07	100.1	113	20	229	3.78
150	6"	F07	110-165	110	F07+F10	183.3	136	20	266	6.09
200	8"	F10	250-350	125	F07+F10	327.4	161	30	337	10.86
250	10"	F10	350-400	140	F10+F12	482.9	178	30	377	13.77
300	12"	F10	460-580	160	F10+F12	670.4	200	30	412	20.15
350	14"	F10	800-1100	190	F10+F14, F12	1053.9	232	30	488	28.41
400	16"	F14	1100-1330	210	F14	1471.3	255	30	550	40.03
450	18"	F14	1700-2300	240	F14, F16	2282.1	292	30	602	52.6
500	20"	F16	2300-2900	270	F16	3207.5	331	30	672	73.64
600	24"	F16	2500-3250	270	F16	3207.5	331	30	672	73.64

Sizing - Fig.541 Air/spring (Spring return)

Fig.225/226				Sizing - Fig.541 Spring return - Air supply 6bar							
DN	INCH	ISO5211	Torque /Nm	Size	ISO5211	Torque air /Nm 0° - 90°	Torque spring /Nm 90° - 0°	C [mm]	P [mm]	L [mm]	[kg]
50	2"	F05	18-25	75	F05+F07	25.7	42.5	100	20	210	3.29
65	2 ½"	F05	20-27	85	F05+F07	39.7	60.3	113	20	229	4.26
80	3"	F05	40-48	95	F05+F07	53	87.6	123	20	264	5.86
100	4"	F07	50-65	110	F07+F10	68.6	114.6	136	20	266	7.17
125	5"	F07	80-110	125	F07+F10	122.4	205	161	30	337	12.54
200	8"	F10	250-350	190	F10+F14, F12	436.2	617.7	232	30	488	33.81
250	10"	F10	350-400	190	F10+F14, F12	436.2	617.7	232	30	488	33.81
300	12"	F10	460-580	210	F14	589	882.4	255	30	550	48.43
350	14"	F10	800-1100	270	F16	1342.8	1926.8	331	30	672	90.6
400	16"	F14	1100-1330	270	F16	1342.8	1926.8	331	30	672	90.6

Note: Please consider a safety factor of 1.2~1.3 on valve torque for sizing for actuators; Please note that the torque can be adjusted according to the actual working pressure for special requirements. Please contact Coreline for details.

Coreline

The contents of this catalogue are confidential and proprietary to Coreline, we reserve the right to change the specifications without any notice.

CORELINE LTD.

Add: No.4 Wangjiang Road, Muqiao Town, Zhengpugang New District, 238200 Hexian, Ma'anshan City, Anhui Province, China

Http: // www.coreline.dk

E-mail: mail@coreline.cn