

## 3PC Ball valve

Fig.135

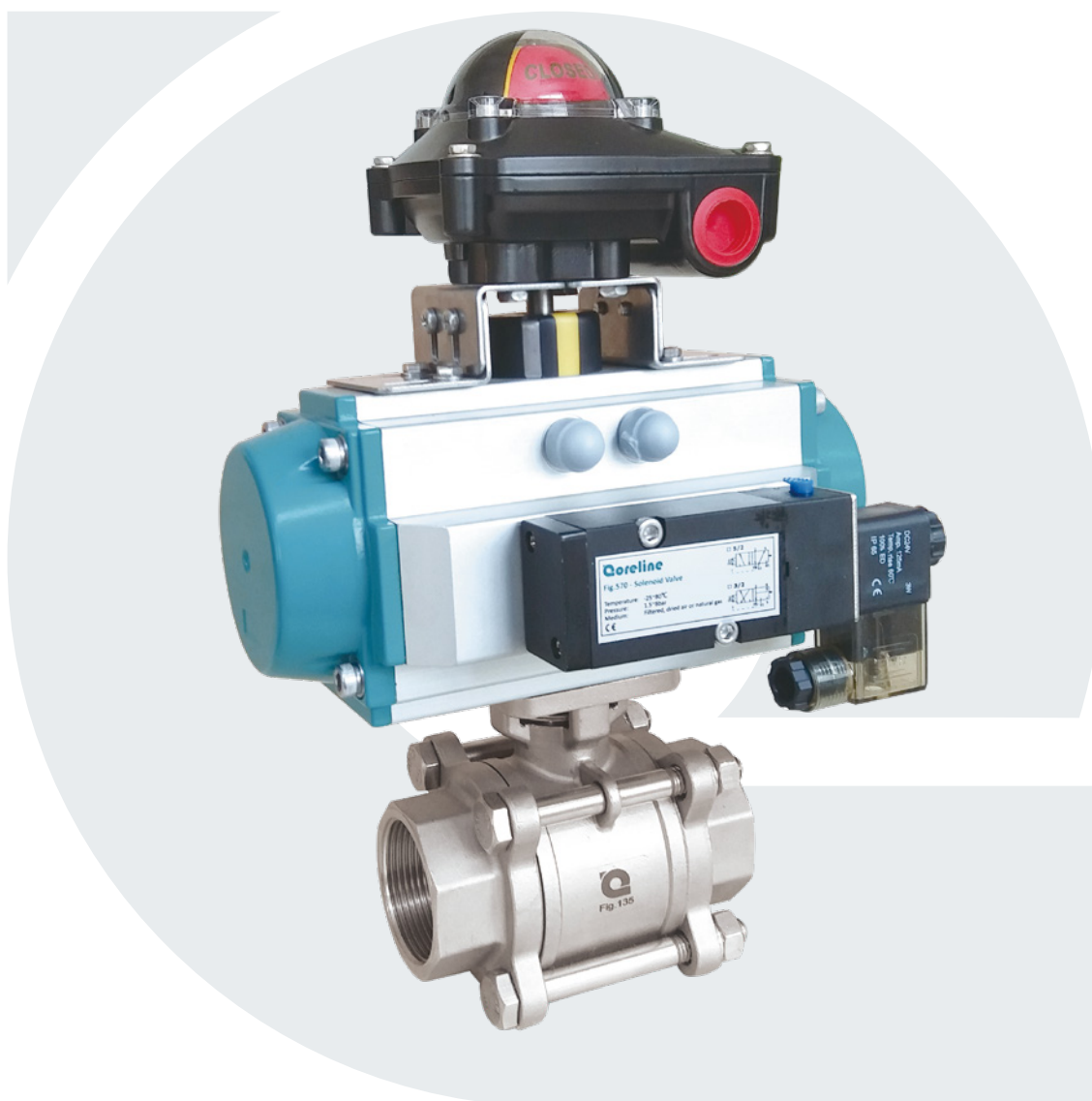

[www.coreline.dk](http://www.coreline.dk)

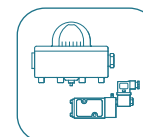
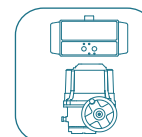
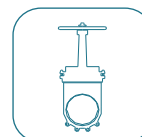
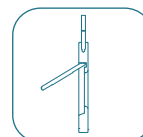
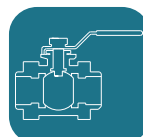
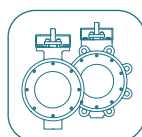
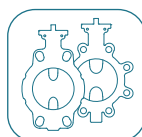

# General specifications

## Features

- Wax casting with excellent surface finish.
- Full bore for better Kv value.
- Solid ball for high performance tasks.
- Pressure relief hole in ball slot.
- Anti-static devices for ball - stem - body.
- Blow-out proof stem.
- ISO5211 direct mounting pad for easy automation.
- Thread and BW ends face to face dimension confirms to DIN3202 M3.

## Specifications

Connection:	Thread ends BSPP - ISO228/1 Butt weld ends - ISO1127, EN12627 Flanged ends - EN1092-1
Size range:	1/4" to 4"
Pressure rating:	Thread/BW ends: 1/4" - 2": PN63 2 1/2" - 4": PN40 Flanged ends: 1/2" - 2": PN40/PN16 2 1/2" - 4": PN16
Face to face:	Thread/BW ends: DIN3202 M3 Flanged ends: DIN3202 F1
Body:	Stainless steel, carbon steel
Seat:	PTFE. Other materials available on request
Operation:	Hand lever, pneumatic actuator, electric actuator



ATEX, CE, SIL and EU1935/2004 (European food approval) for Coreline ball valves.

## Stem sealing system

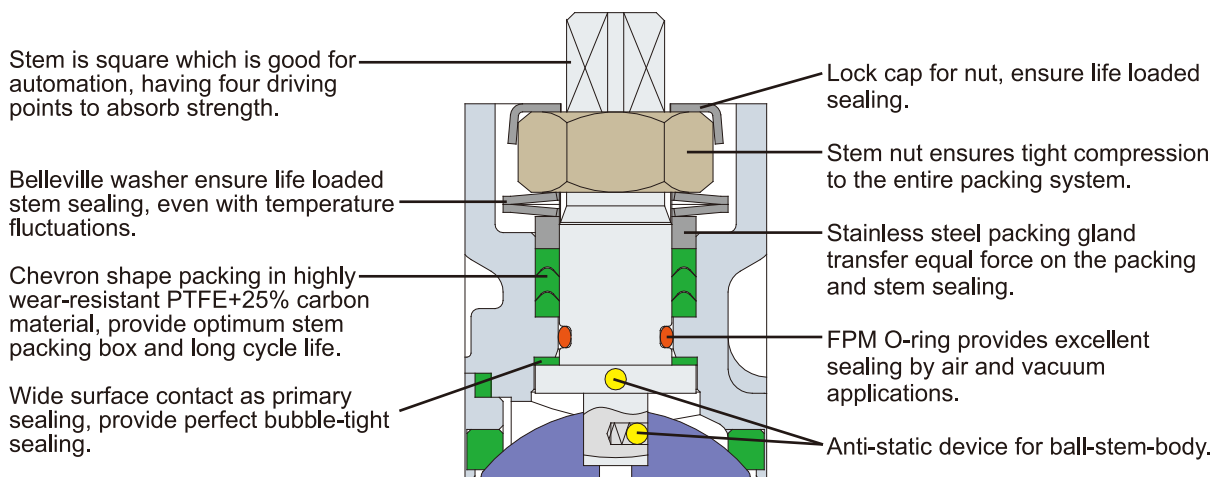

# Material part list

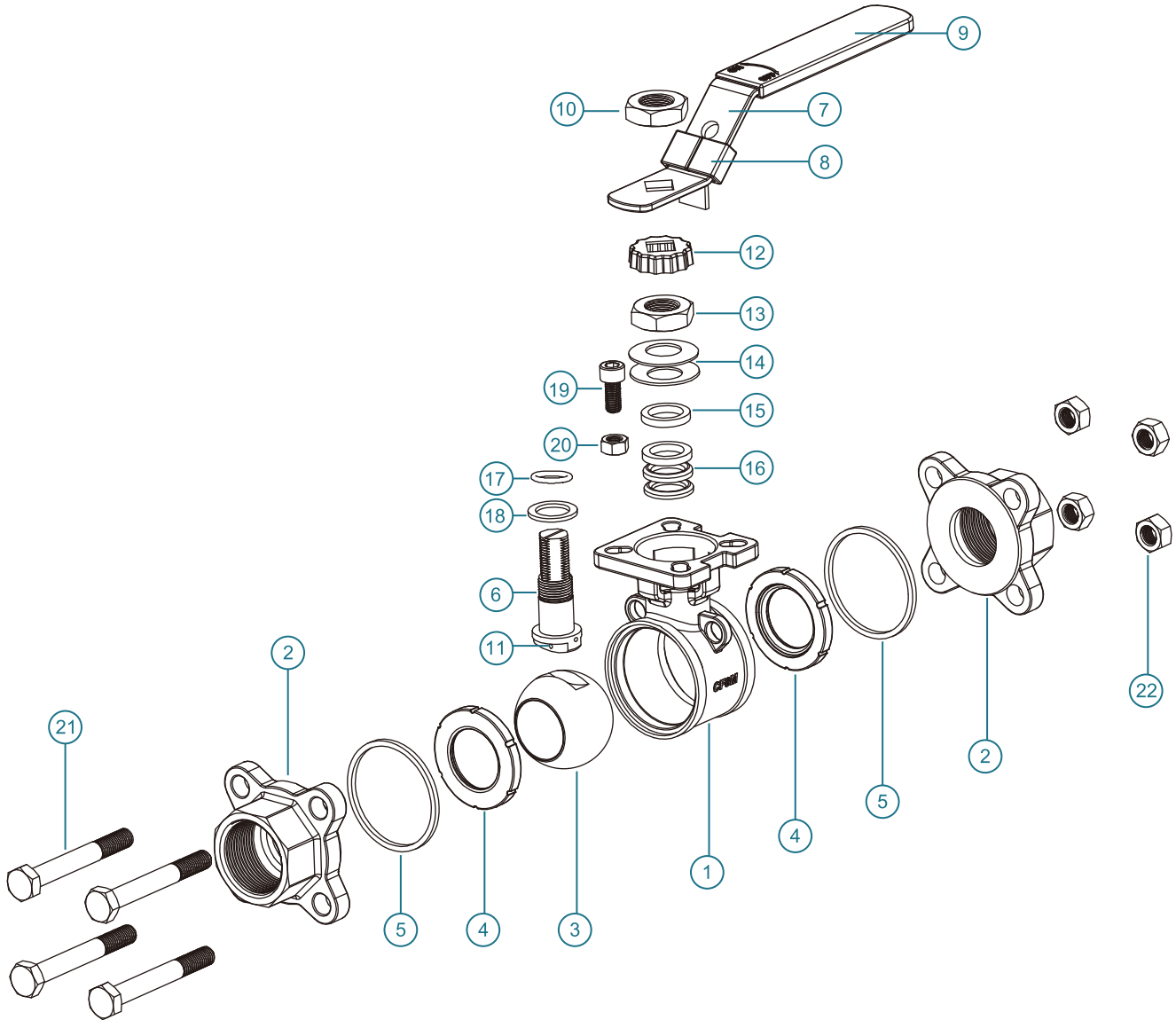

## Material part list

No.	Part name	Material	No.	Part name	Material
1	Body	A351 CF8M	9	Handle sleeve	Vinyl
		A351 CF8	10	Nut	SS304
		A216 WCB	11	Anti-static device	SS316
2	Cap	A351 CF8M	12	Lock cap	SS304
		A351 CF8	13	Nut	SS304
		A216 WCB	14	Belleville washer	SS304
3	Ball	SS316	15	Gland	SS304
		SS304	16	V-ring packing	PTFE
4	Seat	PTFE	17	O-ring	FPM
5	Gasket	PTFE	18	Stem sealing	PTFE
6	Stem	SS316	19	Stop bolt	SS304
		SS304	20	Nut	SS304
7	Handle	SS304	21	Body bolt	SS304
8	Locking device	SS304	22	Nut	SS304

1) Other sealing materials available on request.

# Dimensions

## Dimensions - Thread and BW ends

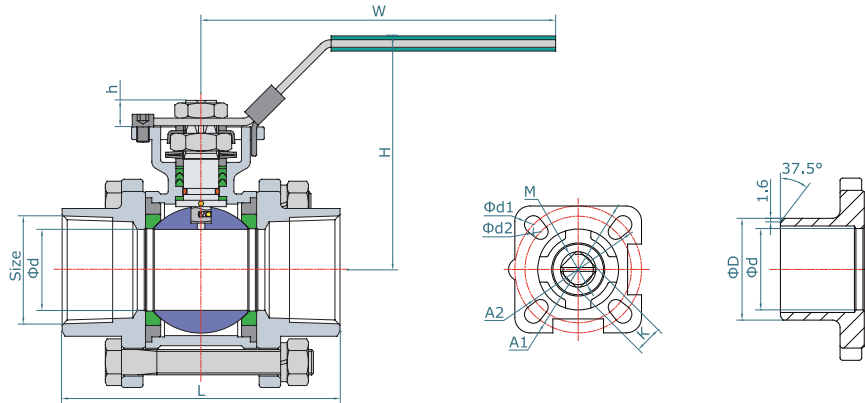

Size		Valve with handle					Mounting flange						Stem		
INCH	DN	d	L	H	W	D	ISO5211	A1	d1	ISO5211	A2	d2	K	h	M
1/4"	8	10	60	77	110	14	F04	42	6	F03	36	6	9	10	M12
3/8"	10	12	60	77	110	17.5	F04	42	6	F03	36	6	9	10	M12
1/2"	15	15	75	77	110	21.6	F04	42	6	F03	36	6	9	10	M12
3/4"	20	20	80	81.5	120	27.2	F04	42	6	F03	36	6	9	10	M12
1"	25	25	90	90	140	34	F05	50	7	F04	42	6	11	12	M14
1 1/4"	32	32	110	94.5	140	42.8	F05	50	7	F04	42	6	11	12	M14
1 1/2"	40	38	120	104	190	48.6	F07	70	9	F05	50	7	14	15	M18
2"	50	49	140	112	190	60.5	F07	70	9	F05	50	7	14	15	M18
2 1/2"	65	64	185	120	230	76.3	F07	70	9	F05	50	7	14	15	M18
3"	80	76	205	132	260	90	F10	102	11	F07	70	9	17	18	M22
4"	100	100	240	160	300	116	F10	102	11	F07	70	9	17	18	M22

## Dimensions - Flange ends

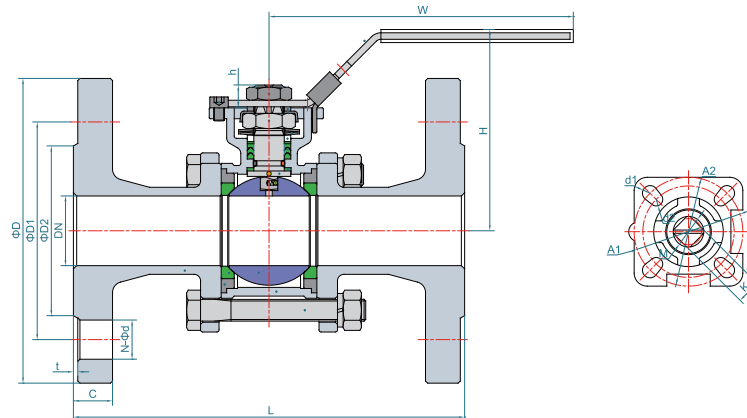

Size		Valve with handle								Mounting flange						Stem			
INCH	DN	D	D1	D2	C	t	N-d	L	H	W	ISO5211	A1	d1	ISO5211	A2	d2	K	h	M
1/2"	15	95	65	45	16	2	4-14	130	77	120	F04	42	6	F03	36	6	9	10	M12
3/4"	20	105	75	58	18	2	4-14	150	82	120	F04	42	6	F03	36	6	9	10	M12
1"	25	115	85	68	18	2	4-14	160	90	140	F05	50	7	F04	42	6	11	12	M14
1 1/4"	32	140	100	78	18	2	4-18	180	95	140	F05	50	7	F04	42	6	11	12	M14
1 1/2"	40	150	110	88	18	3	4-18	200	104	190	F07	70	9	F05	50	7	14	15	M18
2"	50	165	125	102	20	3	4-18	230	112	190	F07	70	9	F05	50	7	14	15	M18
2 1/2"	65	185	145	122	18	3	4-18	290	123	230	F07	70	9	F05	50	7	14	15	M18
3"	80	200	160	138	20	3	8-18	310	145	260	F10	102	11	F07	70	9	17	18	M22
4"	100	220	180	158	20	3	8-18	350	170	300	F10	102	11	F07	70	9	17	18	M22

# Technical specifications

## Technical data

Size		1) Breakaway torque	Body bolt torque	2) Kv - 90°	Weight -BW type
INCH	DN	[Nm]	[Nm]	[m³/h]	[kg]
1/2"	15	8	25-35	10	0.7
3/4"	20	10	25-35	28	0.8
1"	25	17	25-35	48	1.1
1 1/4"	32	24	50-60	71	1.7
1 1/2"	40	27	50-60	103	2.6
2"	50	36	50-60	208	3.8
2 1/2"	65	53	55-65	275	7.2
3"	80	70	90-100	500	11.8
4"	100	120	90-100	880	19.2

1) Torque value is measured without load under room temperature.

It is based on Fig.135 with PTFE seat and includes 30% safety factor.

2) Kv-value rated flow coefficients (m³/h at 1 bar ΔP).

The flow coefficient - Kv can be calculated according to the below formula:

Liquid:

$$K_v = Q * \sqrt{\frac{W}{\Delta P}}$$

K<sub>v</sub>: Flow coefficient

Q: Maximum flow volumn, m³/h

W: Exact weight, kg/m³

ΔP: Pressure loss, bar

Gas:

$$K_v = \frac{V_N}{514} * \sqrt{\frac{G * T}{\Delta P * P_d}}$$

V<sub>N</sub>: Maximum flow, Nm³/h

G: Exact weight, kg/Nm³

T: Absolute temperature, Kelvin

P<sub>d</sub>: Absolute pressure downstream, bar

## Pressure temperature curve - Thread / Butt weld ends

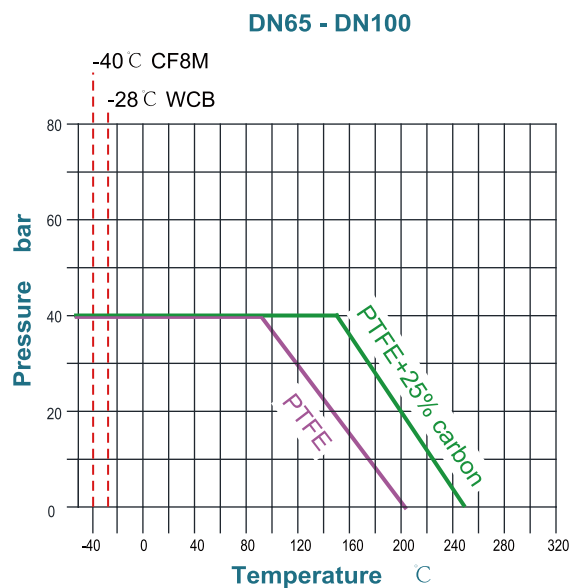
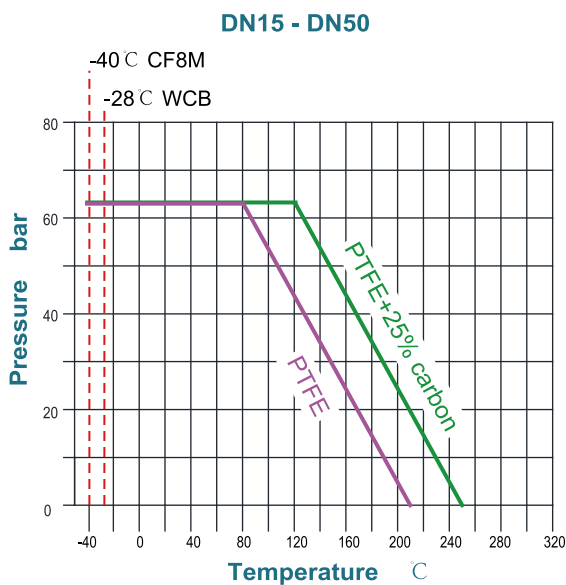

**OBS:** The pressure/temperature specifications are maximum application limits as declared by Coreline. The values can be influenced by all application factors such as size, seat design (open or encapsulated body bolts) and pressure/temperature limitations given by ASME B16.34.

## Sizing - Pneumatic actuator

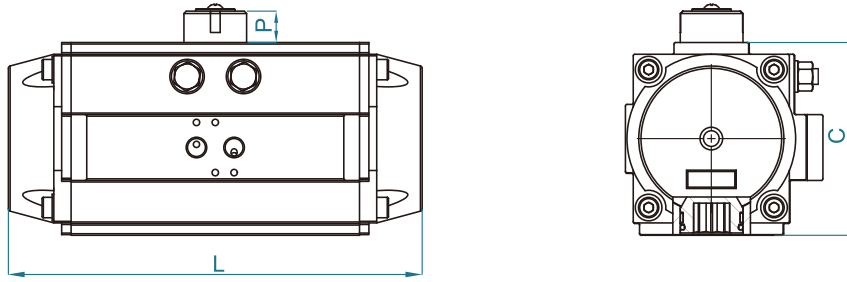

### Double acting sizing - Air supply 6bar

Fig.135			Sizing - Fig.540 Double acting							
INCH	DN	Torque /Nm	SIZE	Output torque /Nm	ISO5211	Stem	C /mm	P /mm	L /mm	[kg]
1/2"	15	8	40	14.3	F03+F05	11×11	60	20	110	1
3/4"	20	10	40	14.3	F03+F05	11×11	60	20	110	1
1"	25	17	50	21.6	F03+F05	11×11	70	20	154	1.13
1 1/4"	32	24	65	43.9	F03+F05	14×14	89	20	189	1.97
1 1/2"	40	26	65	43.9	F03+F05	14×14	89	20	189	1.97
2"	50	36	75	68.2	F05+F07	14×14	100	20	210	2.93
2 1/2"	65	53	75	68.2	F05+F07	14×14	100	20	210	2.93
3"	80	70	85	100.1	F05+F07	17×17	113	20	229	3.78
4"	100	120	95	140.6	F05+F07	17×17	123	20	264	5.14

### Spring return sizing - Air supply 6bar

Fig.135			Sizing - Fig.541 Spring return								
INCH	DN	Torque /Nm	SIZE	Torque air /Nm 0° - 90°	Torque spring /Nm 90° - 0°	ISO5211	Stem	C /mm	P /mm	L /mm	[kg]
1/2"	15	8	50 S12	13.2 - 9.3	12.4 - 8.4	F03+F05	9×9	70	20	154	1.25
3/4"	20	10	65 S10	26.5 - 17.7	26.2 - 17.4	F03+F05	11×11	89	20	189	2.21
1"	25	17	65 S10	26.5 - 17.7	26.2 - 17.4	F03+F05	11×11	89	20	189	2.21
1 1/4"	32	24	75 S12	42.5 - 27.7	40.4 - 25.7	F05+F07	14×14	100	20	210	3.29
1 1/2"	40	26	75 S12	42.5 - 27.7	40.4 - 25.7	F05+F07	14×14	100	20	210	3.29
2"	50	36	85 S12	60.3 - 37.5	62.5 - 39.7	F05+F07	14×14	113	20	229	4.26
2 1/2"	65	53	95 S12	87.6 - 57.0	83.6 - 53	F05+F07	14×14	123	20	264	5.86
3"	80	70	110 S12	114.6 - 73.2	110 - 68.6	F07+F10	14×14	136	20	266	7.17
4"	100	120	125 S12	205 - 134	193.3 - 122.4	F07+F10	17×17	161	30	337	12.54

### Bracket and coupling

- Stainless steel.
- Using as adapter bracket to change the ISO connection.
- Using as function of isolation or protect the actuator because of the temperature in the system.



# Installation guide

## Usage

Maximum lifetime of the valve can be maintained under normal conditions and in accordance with pressure temperature rating and corrosion data.

## Operation instructions

- The opening and closing of the valve is done by turning the handle a quarter turn (90° turn).

The valve handle is marked showing proper rotation direction for "ON" and "OFF" positions. Rotation is clockwise for "OFF" (closed) and counterclockwise for "ON" (open) (except the pipe handle for big sizes).



- Valve in OPEN position: The handle is in line with the valve or pipeline.
- Valve in CLOSED position: The handle is across the pipeline.

## Installation instructions

- Make sure the spacing between the pipe endings correspond to the face-to-face dimensions of the ball valve. The pipeline should be supported.
- Ensure Working conditions (pressure and temperature) are in accordance with the specified capacity of the product being installed.
- Make sure that the construction material of the ball valve is compatible with the media flowing in the pipeline.
- The pipeline should be checked for proper alignment before installation.
- The pipes must be purged before installation.
- The ball valve is recommend to be installed with stem towards up on pipeline, since the deposited dirt may damage the seal if turned downward.

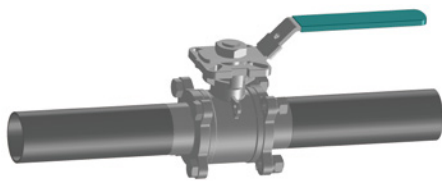

YES



NO

## Installation of thread ends type

- Do not disassemble the valve before installation.
- Sealant is applied to the pipe thread (Packing yarn, Teflon tape, Loctite etc.).
- Apply wrench only to the hexagon part of the valve end that is to be connected.
- Valves in oxygen service can only be sealed with oxygen compatible thread sealant.

# Installation guide

## Installation of weld ends type

- With the ball valve open, disassemble the body from the spot welded connection ends and place the body in a clean and safe place.
- Make sure that the connection ends are aligned. Complete the welding of both connection ends to the pipe.
- Carefully place the open ball valve (body) between the cleaned and cooled connection ends. Make sure that the joint gasket is not scratched against the connection ends, which may cause leaks during operation.
- With the ball valve open carefully tighten the bolts evenly in a star pattern with a torque wrench until the below torques are obtained.

SIZE	DN	15	20	25	32	40	50	65	80	100
	INCH	1/2"	3/4"	1"	1 1/4"	1 1/2"	2"	2 1/2"	3"	4"
Torque	Nm	25-35	25-35	25-35	50-60	50-60	50-60	55-65	90-100	90-100

- With the ball valve open flush the pipes to keep it free of dirt, burrs and welding residues in order to avoid damage to the seat or ball surface which will degrade overall performance overtime. During this procedure the valve must be in the open position and not be operated until the flushing has been finished.

## Installation of flanged ends type

- Make sure that the connection flanges are aligned in pipeline. Complete the welding of both flanges to the pipe.
- Carefully place the gaskets and open ball valve between two flanges. Make sure that the joint gasket is not scratched against the flanged ends, which may cause leakage during operation.
- With the ball valve open carefully tighten the bolts evenly in a star pattern with a torque wrench.

## Ball valve function test

- Gradually open and close the valve until a full 90° turn is obtained. In this way you make sure that the seat is shaped against the ball. This is particularly important when installing new seats.

## Storage instructions

- It is recommend to keep the original packing material during storage.
- Store the valve in a clean, dry, consistent temperature environment to protect it against dirt and damp.
- It is recommend that the valve keep in fully open position in storage period.
- Keep the plastic covers on both ends of ball valve to prevent any dirt from getting inside ball cavity during storage.

The contents of this catalogue are confidential and proprietary to Coreline, we reserve the right to change the specifications without any notice.

**CORELINE LTD.**

Add: No.4 Wangjiang Road, Muqiao Town, Zhengpugang New District, 238200 Hexian, Ma'anshan City, Anhui Province, China

Http: // [www.coreline.dk](http://www.coreline.dk)

E-mail : [mail@coreline.cn](mailto:mail@coreline.cn)