

## Union ball valve

**Fig.120D : Degreased for Oxygen**

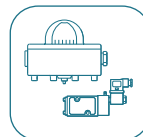

[www.coreline.dk](http://www.coreline.dk)

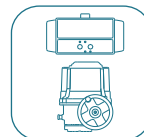
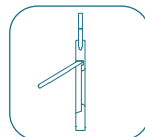
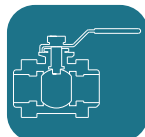
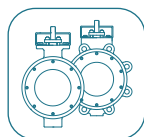
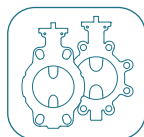

## Fig.120D union ball valve - Degreased for Oxygen

- Degreased for oxygen application.
- CE and EU1935/2004 approved.
- Certificate EN10204 - 3.1.

**Size:** 1/2", 1"

**Pressure rating:** PN63

**Temperature range:** -20 ~ +180 °C



**CE**  CE and EU1935/2004 (European food approval)

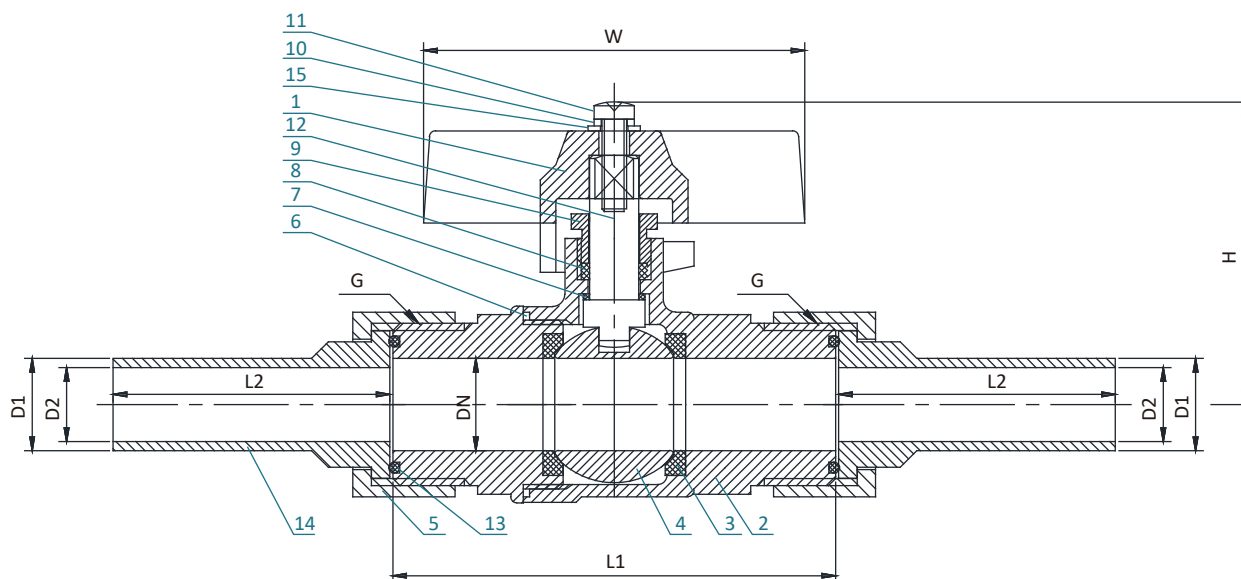

### Material part list

NO.	NAME	MATERIAL	QTY	NO.	NAME	MATERIAL	QTY
1	HANDLE	CF8M	1	9	GLAND NUT	304	1
2	BODY	CF8M	1	10	SPRING WASHER	304	1
3	BALL SEAT	PTFE	2	11	BOLT	304	1
4	BALL	316	1	12	STEM	316	1
5	NUT	CF8M	2	13	O-RING	VITON	2
6	END SEAL	PTFE	1	14	CONNECTING JOINT	316L	2
7	THRUST WASHER	PTFE	1	15	WASHER	304	1
8	STEM PACKING	PTFE	1				

### Dimensions

INCH	DN	D1	D2	L1	L2	H	W	G
1/2"	15	15	12	72	45	49.2	62	G3/4"
1"	25	28	25	100	60	61.5	62	G 1 1/4"

# Coreline

**CORELINE LTD.**

Add: No.4 Wangjiang Road, Muqiao Town, Zhengpugang New District,  
238200 Hexian, Ma'anshan City, Anhui Province, China

The contents of this catalogue are confidential and proprietary to Coreline, we reserve the right to change the specifications without any notice.

Http: // [www.coreline.dk](http://www.coreline.dk)

E-mail : [mail@coreline.cn](mailto:mail@coreline.cn)